

PUMP PERFORMANCE CURVES

TYPE: SUBMERSIBLE DRAINAGE PUMP

MODEL: 50TSM0.4

FREQUENCY: 50Hz

STANDARD SPECIFICATIONS

DISCHARGE BORE

50 mm

HEAD

Max: 12 m

Rated: 10 m

CAPACITY

Max: 0.24 m³/min

Rated: 0.13 m³/min

MOTOR OUTPUT

0.4 kW

PHASE x VOLTAGE

1 Øx 220 V

CURRENT

3.0 A

POLES/REVOLUTION

2 P/ S.S.2850 min⁻¹

STARTING METHOD

Direct-on-line start

INSULATION CLASS

F

60
50
40
30
20
10
0
0.8
0.6
0.4

12
9
6
3

50TSM0.4
50Hz

TOTAL HEAD

PUMP EFF.

INPUT

%
PUMP
EFF.

kW
INPUT
(P1)

m
TOTAL
HEAD

0
0

5
0.1

10
0.1

15

m³/h
m³/min
Capacity

SOLIDPUMP EUROPE SIA

DIMENSION DRAWING
TYPE: **SUBMERSIBLE DRAINAGE PUMP**

MODEL: 50TSM0.4

Model	N.W(kg)
50TSM0.4	15

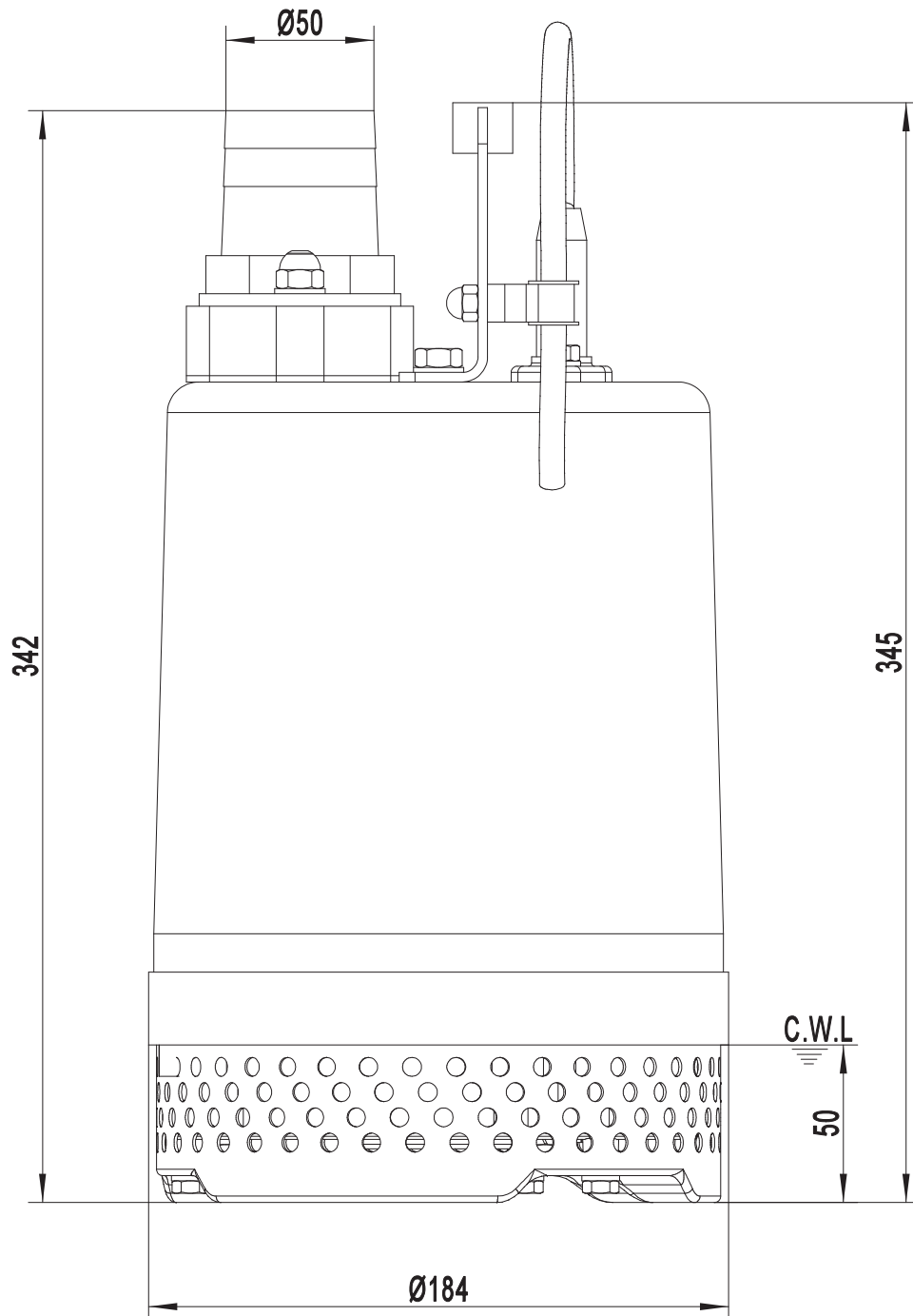

C.W.L.:Continuous Running Water Level.

SOLIDPUMP EUROPE SIA

DIMENSION DRAWING

TYPE: SUBMERSIBLE DRAINAGE PUMP

MODEL: 50TSM0.4

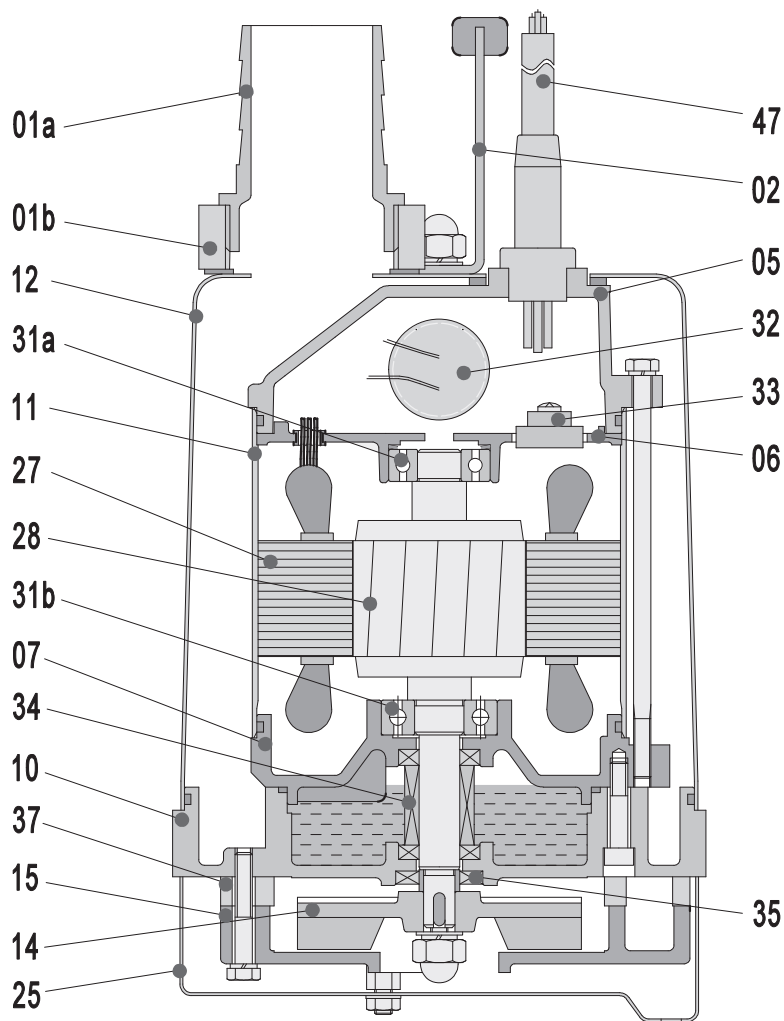

※Optional:AISI304SS

Item No.	Part name	Material	Item No.	Part name	Material
01a	Hose coupling	ABS	25	Strainer	AISI304SS
01b	Hose coupling	PA66	27	Stator	
02	Handle	Rubber&AISI304SS	28	Rotor	Shaft:AISI304SS
05※	Upper cover	Cast iron	31a	Bearing	Ball bearing
06	Up-Bearing house	Aluminum die casting	31b	Bearing	Ball bearing
07※	Bearing house	Cast iron	32	Capacitor	
10※	Seal house	Cast iron	33	Motor protector	
11	Motor casing	AISI304SS	34	Mechanical seal	Ceramic-Sic/Carbon-Ceramic
12	Outer casing	AISI304SS	35	Oil seal	
14※	Impeller	Ductile iron	37	Gasket	NBR
15※	Diffuser	Cast iron	47	Cable	H07RN-F

Specifications can be changed without notice

Solidpump Europe SIA

Uriekstes iela 14a
Rīga, LV-1005
LATVIA

Tel.: + 371 66968996
E-mail: info@solidpump.com
www.solidpump.com

Ver. 21.11.2022

SOLIDPUMP EUROPE SIA