

PUMP PERFORMANCE CURVES

TYPE: SUBMERSIBLE SLURRY PUMP

MODEL: 200TBS22

FREQUENCY: 50Hz

STANDARD SPECIFICATIONS

DISCHARGE BORE

200 mm

HEAD

Max: 32 m

Rated: 24 m

CAPACITY

Max: 6 m³/min

Rated: 3.33 m³/min

MOTOR OUTPUT

22 kW

PHASE x VOLTAGE

3 Øx 380/400V

CURRENT

42 A

POLES/REVOLUTION

4 P/ S.S.1450 min⁻¹

STARTING METHOD

Star-Delta start

INSULATION CLASS

F

60
50
40
30
20
10
0
25
20
15

32
24
16
8

TOTAL HEAD
PUMPEFF.

INPUT

200TBS22
50Hz

%	kW	m	0	60	120	180	240	300	360	m ³ /h
PUMP EFF.	INPUT (P1)	TOTAL HEAD	0		2.0		4.0		6.0	m ³ /min
										Capacity

SOLIDPUMP EUROPE SIA

DIMENSION DRAWING
TYPE: **SUBMERSIBLE SLURRY PUMP**

MODEL: 200TBS22

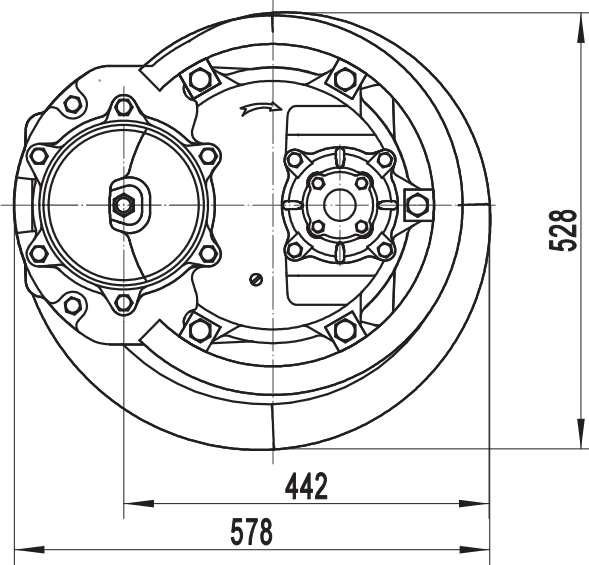

Model	N.W(kg)
200TBS22	408

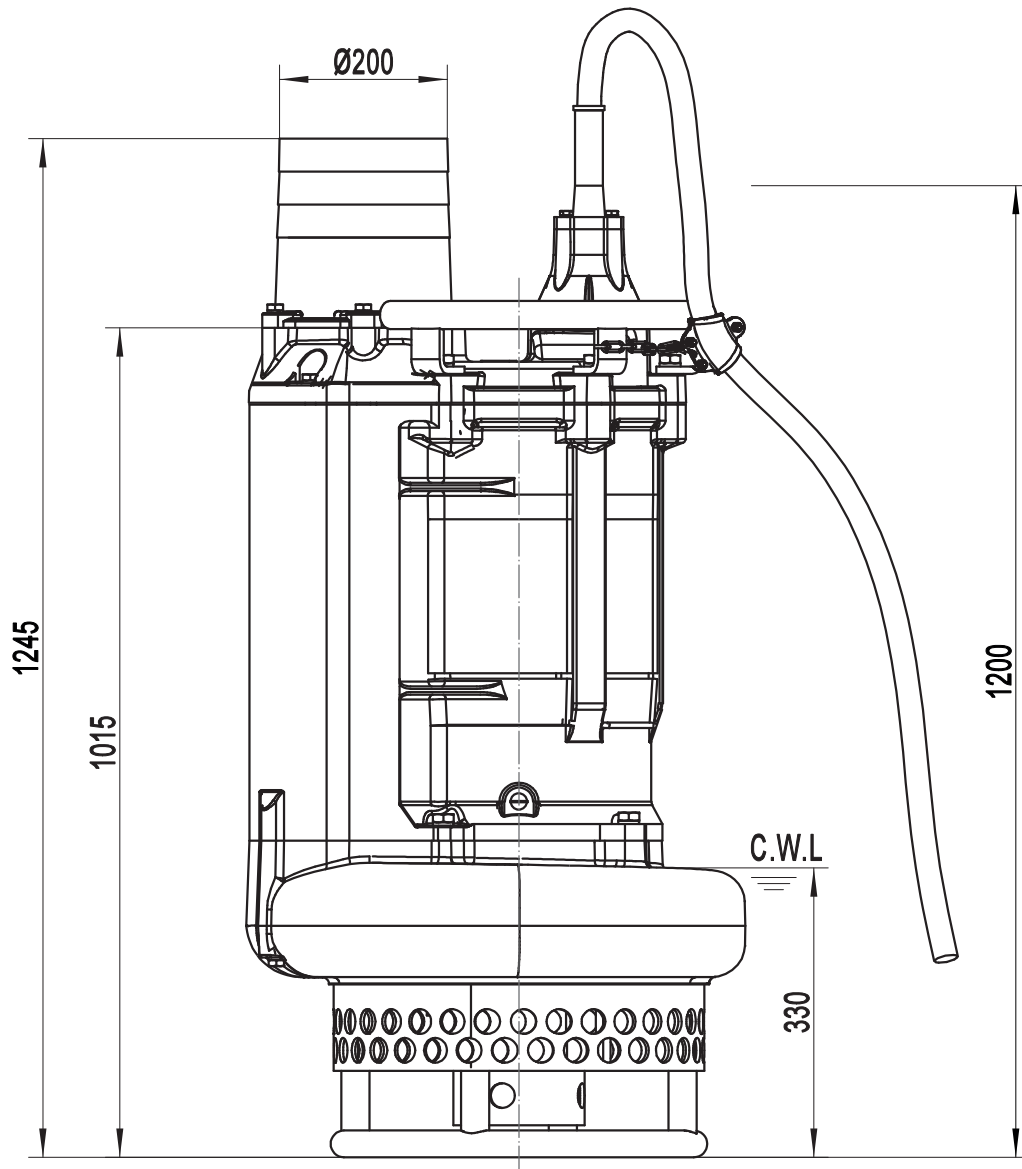

C.W.L.: Continuous Running Water Level.

SOLIDPUMP EUROPE SIA

DIMENSION DRAWING
TYPE: SUBMERSIBLE SLURRY PUMP

MODEL: 200TBS22

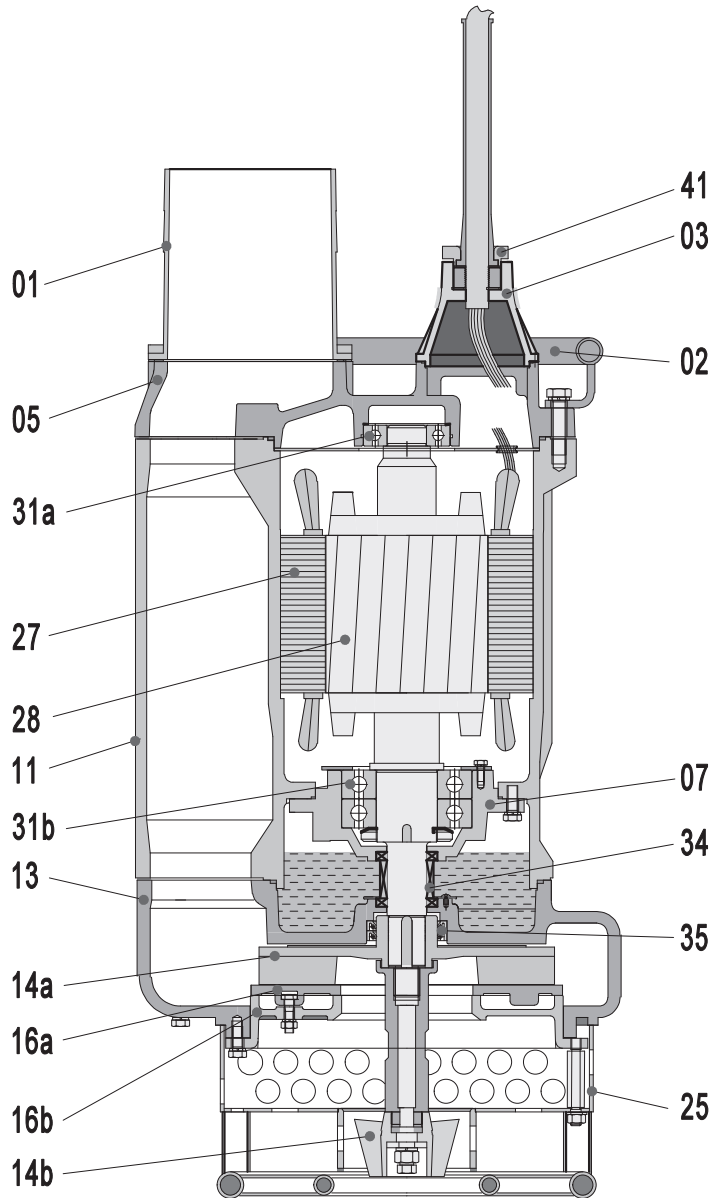

Item No.	Part name	Material	Item No.	Part name	Material
01	Hose coupling	Cast iron	25	Strainer	Steel
02	Handle	Steel	27	Stator	
05	Upper cover	Cast iron	28	Rotor	Shaft:AISI420SS
07	Bearing house	Cast iron	31a	Bearing	Ball bearing
11	Motor body	Cast iron	31b	Bearing	Ball bearing
13	Pump body	Cast iron	34	Mechanical seal	Tc-Sic/Sic-Sic
14a	Impeller	High chrome alloy	35	Oil seal	
14b	Agitator	High chrome alloy	41	Shim	Cast iron
16a	Inlet plate	High chrome alloy	47	Cable	
16b	Inlet plate	Cast iron			

Specifications can be changed without notice

Solidpump Europe SIA

Uriekstes iela 14a
 Rīga, LV-1005
 LATVIA

Tel.: + 371 66968996
 E-mail: info@solidpump.com
 www.solidpump.com

Ver. 21.11.2022

SOLIDPUMP EUROPE SIA