

PUMP PERFORMANCE CURVES

TYPE: SUBMERSIBLE DRAINAGE PUMP

MODEL: 50MH5.5

FREQUENCY: 50Hz

STANDARD SPECIFICATIONS

DISCHARGE BORE	50 mm	
HEAD	Max: 65 m	Rated: 48 m
CAPACITY	Max: 0.59 m ³ /min	Rated: 0.3 m ³ /min
MOTOR OUTPUT	5.5 kW	
PHASE x VOLTAGE	3 Øx 380/400V	
CURRENT	11.4 A	
POLES/REVOLUTION	2 P/ S.S.2850 min ⁻¹	
STARTING METHOD	Direct-on-line start	
INSULATION CLASS	F/H	

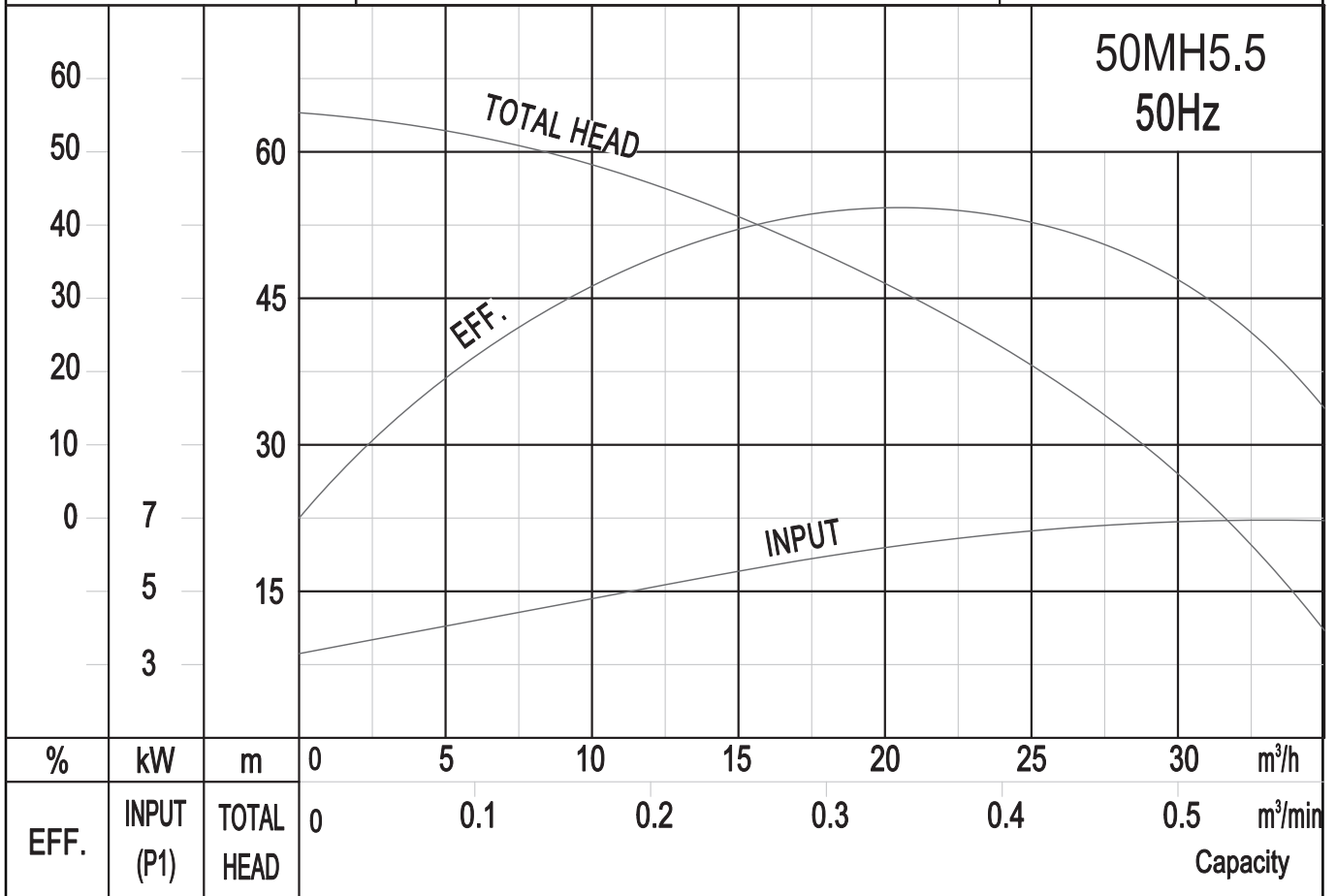

SOLIDPUMP EUROPE SIA

DIMENSION DRAWING
TYPE: SUBMERSIBLE DRAINAGE PUMP

MODEL: 50MH5.5

Model	N.W(kg)
50MH5.5	100

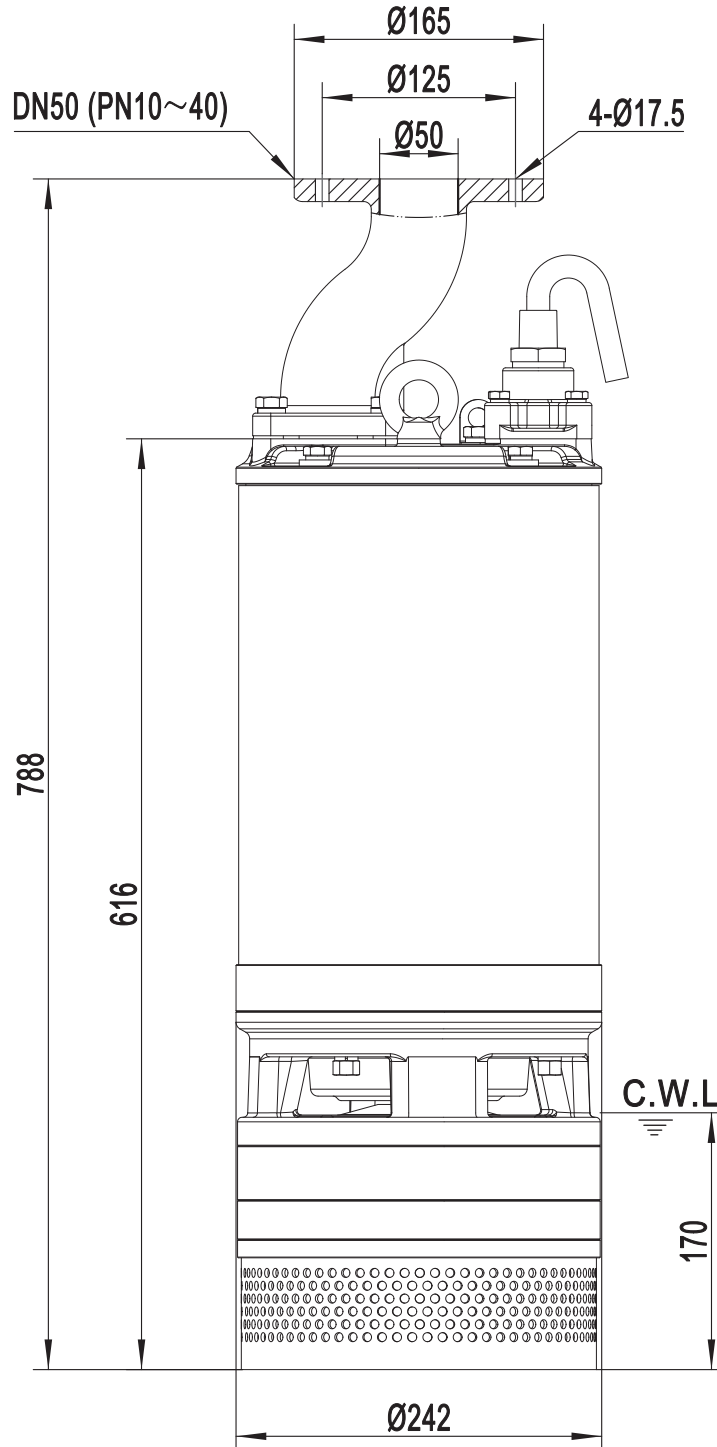

C.W.L:Continuous Running Water Level.

SOLIDPUMP EUROPE SIA

DIMENSION DRAWING

TYPE: **SUBMERSIBLE DRAINAGE PUMP**

MODEL: 50MH5.5

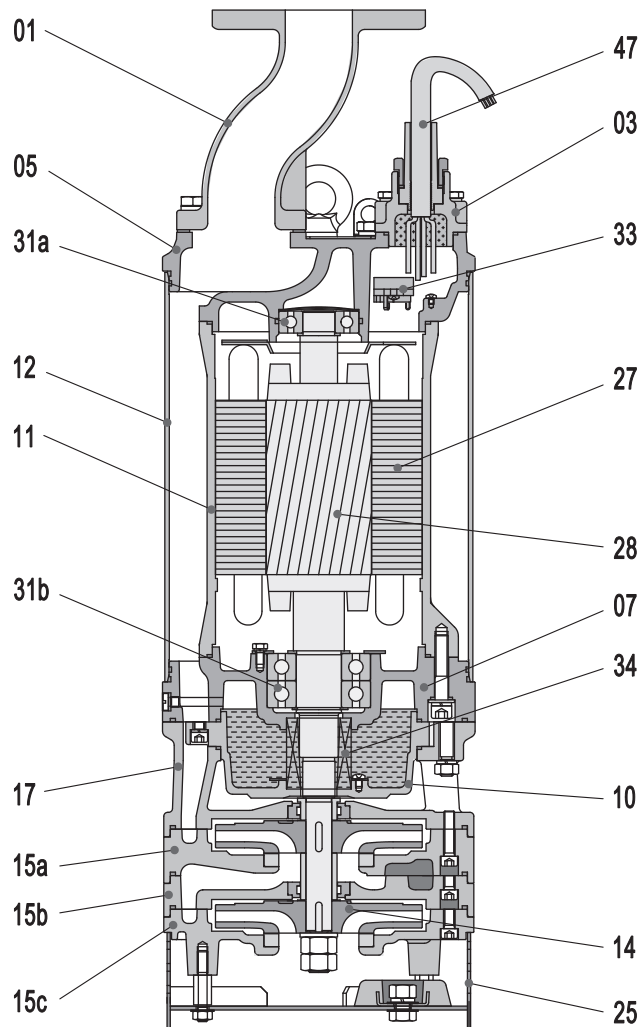

Item No.	Part name	Material	Item No.	Part name	Material
01	Discharge Connection	Ductile iron	15c	Diffuser & Casing	Ductile iron
03	Terminal box	Cast iron	17	Suction interconnector	Ductile iron
05	Upper cover	Cast iron	25	Strainer	
07	Bearing house	Cast iron	27	Stator	
10	Seal bracket	Cast iron	28	Rotor	Shaft:AISI420SS
11	Motor body	Cast iron	31a	Bearing	Ball bearing
12	Outer casing	Steel	31b	Bearing	Ball bearing
14	Impeller	High chrome alloy	33	Motor protector	
15a	Diffuser & Casing	Ductile iron	34	Mechanical seal	Sic-Sic/Sic-Sic
15b	Diffuser & Casing	Ductile iron	47	Cable	

Specifications can be changed without notice

Solidpump Europe SIA

Uriekstes iela 14a
Rīga, LV-1005
LATVIA

Tel.: + 371 66968996
E-mail: info@solidpump.com
www.solidpump.com

Ver. 15.11.2023

SOLIDPUMP EUROPE SIA