

# PUMP PERFORMANCE CURVES

TYPE: SUBMERSIBLE DRAINAGE PUMP

MODEL: 80PSM0.75

FREQUENCY: 50Hz

## STANDARD SPECIFICATIONS

DISCHARGE BORE

80 mm

HEAD

Max: 17 m

Rated: 10 m

CAPACITY

Max: 0.3 m<sup>3</sup>/min

Rated: 0.2 m<sup>3</sup>/min

MOTOR OUTPUT

0.75 kW

PHASE x VOLTAGE

1 Øx 220 V

CURRENT

5.0 A

POLES/REVOLUTION

2 P/ S.S.2850 min<sup>-1</sup>

STARTING METHOD

Direct-on-line start

INSULATION CLASS

F

60  
50  
40  
30  
20  
10  
0

1.1  
0.8  
0.5

16  
12  
8  
4

TOTAL HEAD  
PUMP EFF.

INPUT

80PSM0.75  
50Hz

%	kW	m	0	3	6	9	12	15	18	m <sup>3</sup> /h
PUMP EFF.	INPUT (P1)	TOTAL HEAD	0		0.1		0.2		0.3	m <sup>3</sup> /min Capacity

SOLIDPUMP EUROPE SIA

DIMENSION DRAWING

TYPE: **SUBMERSIBLE DRAINAGE PUMP**

MODEL: 80PSM0.75

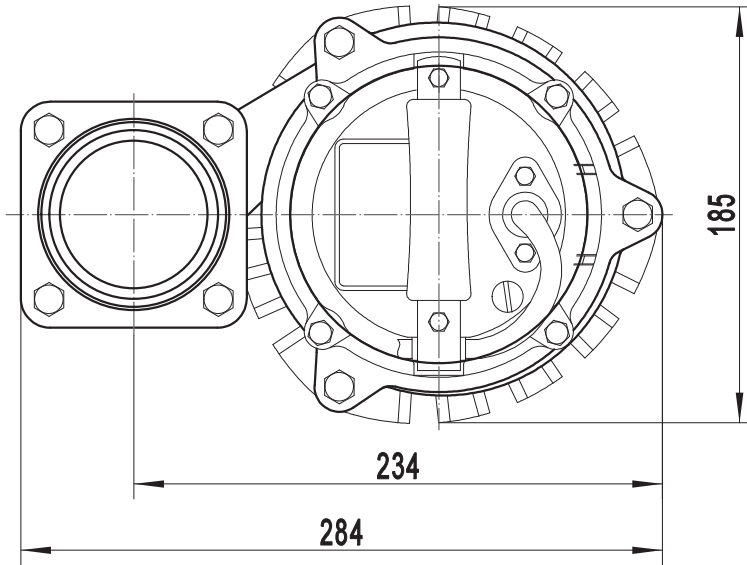

Model	N.W(kg)
80PSM0.75	18

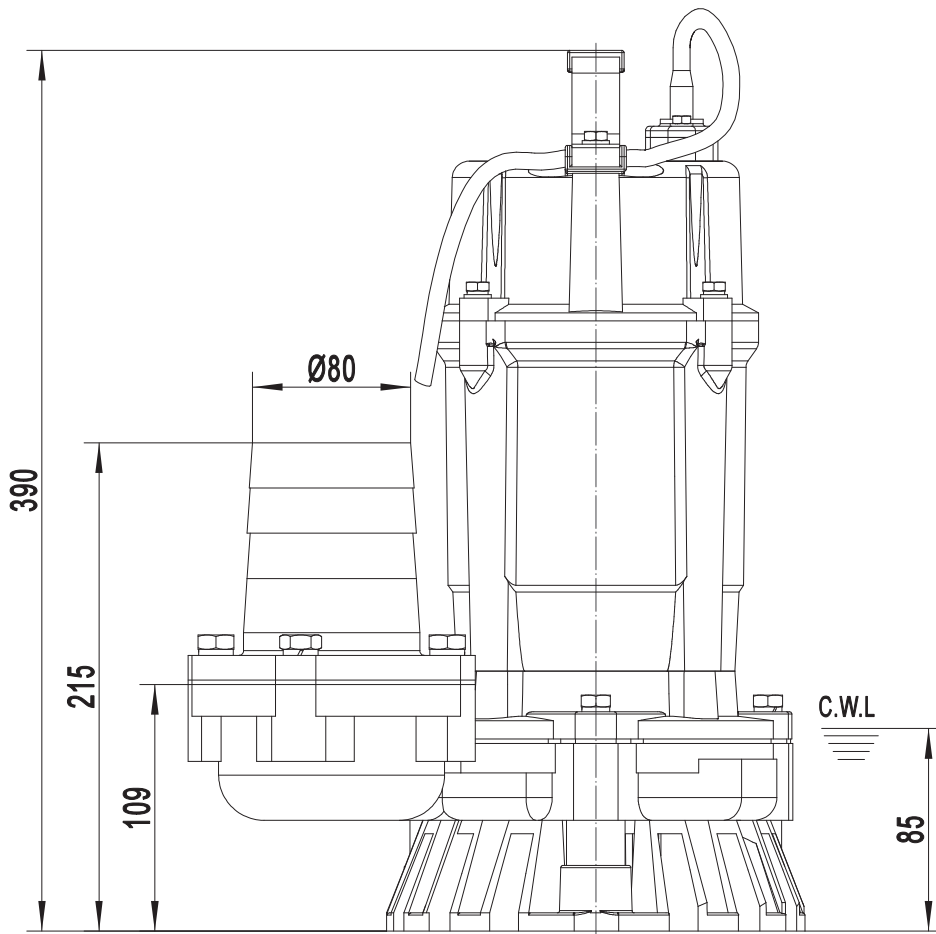

C.W.L.:Continuous Running Water Level.

**SOLIDPUMP EUROPE SIA**

# DIMENSION DRAWING

TYPE: **SUBMERSIBLE DRAINAGE PUMP**

MODEL: 80PSM0.75

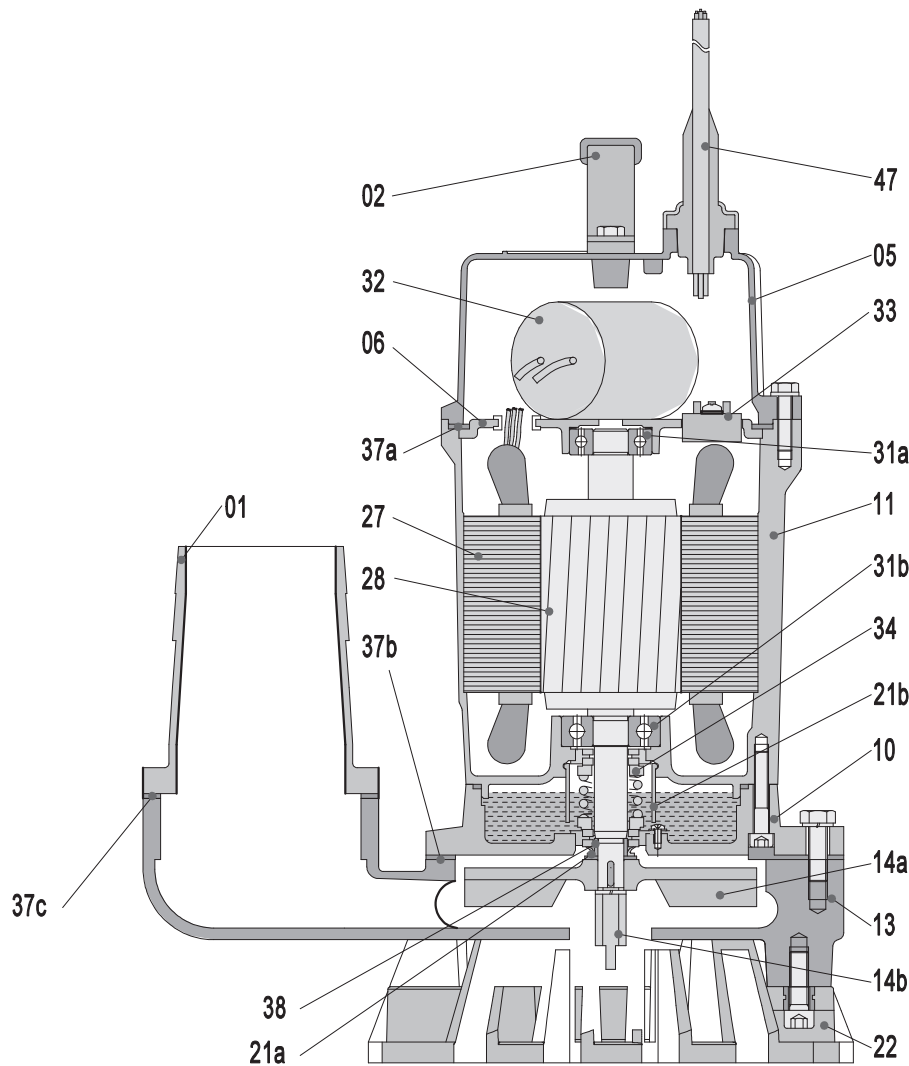

Item No.	Part name	Material	Item No.	Part name	Material
01	Hose coupling	Cast iron	27	Stator	
02	Handle	Rubber&steel	28	Rotor	Shaft:AISI420SS
05	Upper cover	Aluminum die casting	31a	Bearing	Ball bearing
06	Up-Bearing house	Cast iron	31b	Bearing	Ball bearing
10	Seal house	Cast iron	32	Capacitor	
11	Motor body	Aluminum die casting	33	Motor protector	
13	Pump body	Cast iron	34	Mechanical seal	Ceramic-Sic/Carbon-Ceramic
14a	Impeller	Ductile iron	37a	Gasket	NBR
14b	Agitator	Stainless steel	37b	Gasket	NBR
21a	Sand guard	NBR	37c	Gasket	NBR
21b	Oil riser	LDPE	38	Shaft sleeve	AISI420SS
22	Seat assembly	PU	47	Cable	H07RN-F

*Specifications can be changed without notice*

## Solidpump Europe SIA

Uriekstes iela 14a  
Rīga, LV-1005  
LATVIA

Tel.: + 371 66968996  
E-mail: info@solidpump.com  
www.solidpump.com

Ver. 21.11.2022

**SOLIDPUMP EUROPE SIA**