

# PUMP PERFORMANCE CURVES

TYPE: SUBMERSIBLE DRAINAGE PUMP

MODEL: 80TBA2.2

FREQUENCY: 50Hz

## STANDARD SPECIFICATIONS

DISCHARGE BORE	80 mm	
HEAD	Max: 24 m	Rated: 20 m
CAPACITY	Max: 32 m <sup>3</sup> /h	Rated: 12 m <sup>3</sup> /h
SOLIDS DIA	8.5 mm	
MOTOR OUTPUT	2.2 kW	
PHASE x VOLTAGE	3 Øx 400 V	
CURRENT	5.0 A	
POLES/REVOLUTION	2 P/ S.S.2850 min <sup>-1</sup>	
STARTING METHOD	Direct on line	
INSULATION CLASS	F	

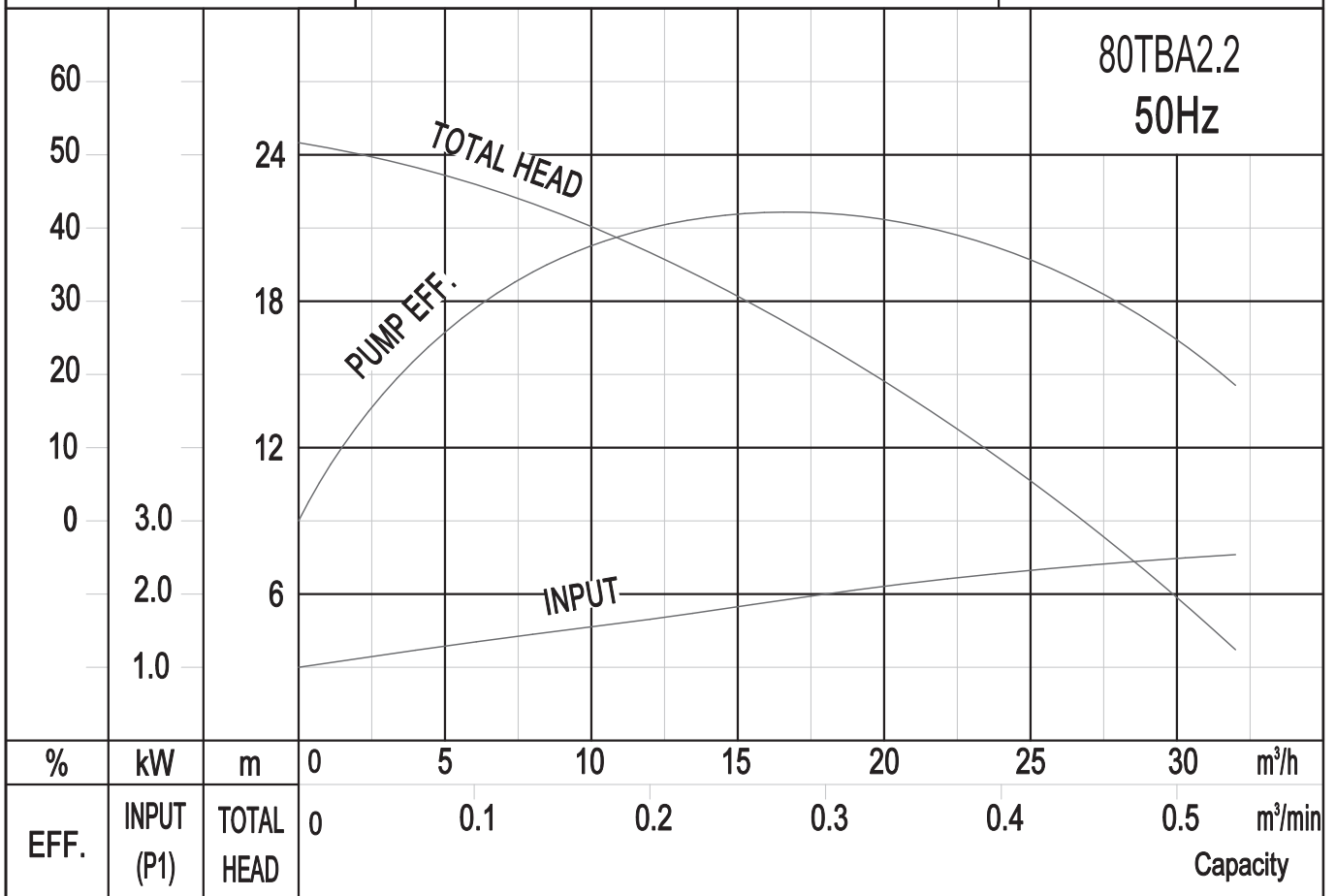

**SOLIDPUMP EUROPE SIA**

SECTIONAL DRAWING  
TYPE: **SUBMERSIBLE DRAINAGE PUMP**

**MODEL: 80TBA2.2**

Model	N.W(kg)
80TBA2.2	25.5

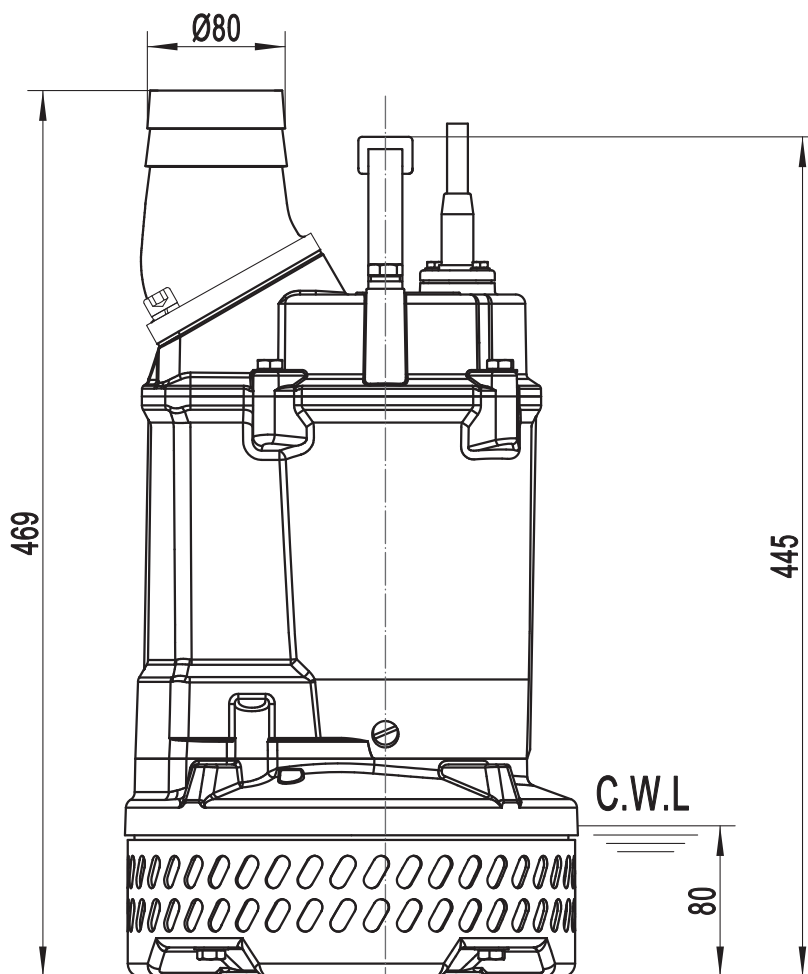
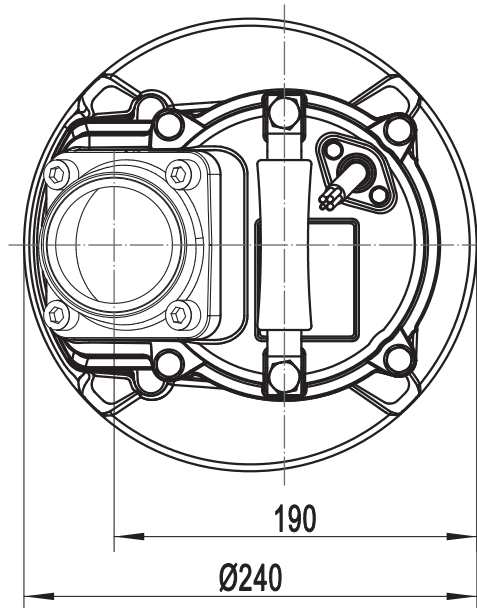

C.W.L.:Continuous Running Water Level.

**SOLIDPUMP EUROPE SIA**

SECTIONAL DRAWING  
 TYPE: **SUBMERSIBLE DRAINAGE PUMP**

MODEL: 80TBA2.2

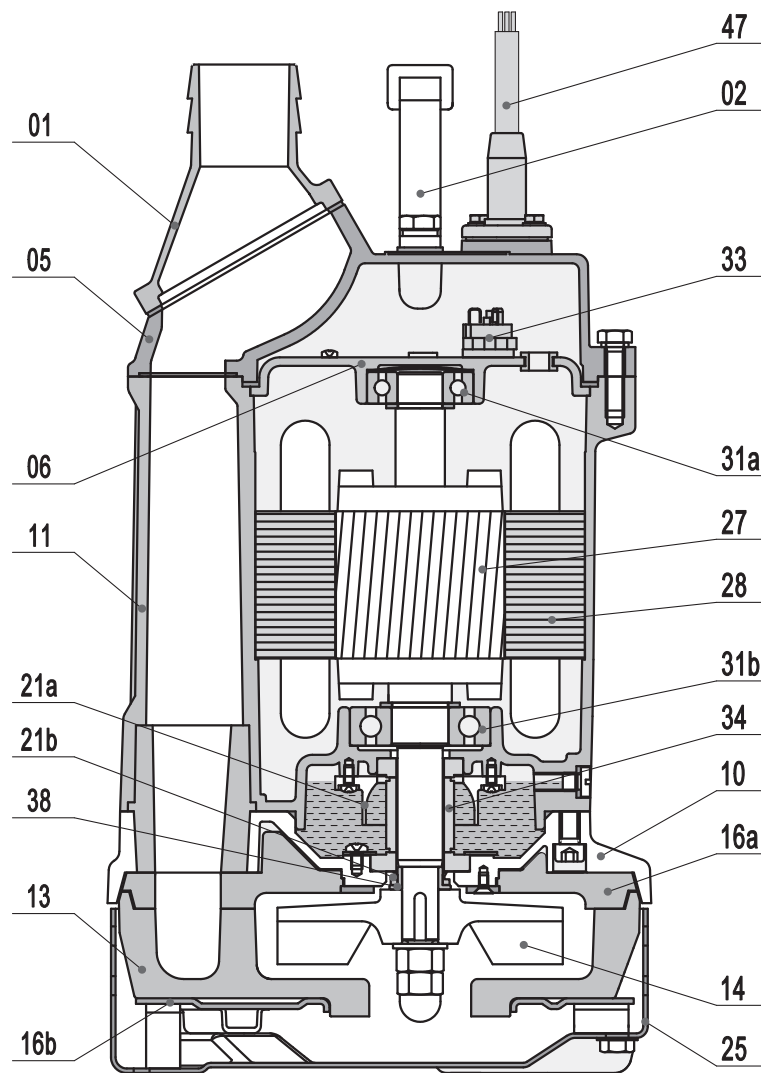

Item No.	Part name	Material	Item No.	Part name	Material
01	Hose coupling	Aluminum die casting	21a	Oil riser	PA66+GF30
02	Handle	Rubber & AISI304SS	21b	Sand guard	NBR
05	Upper cover	Aluminum die casting	27	Stator	
06	Up-Bearing house	Cast iron	28	Rotor	Shaft:Stainless steel
10	Seal house	Aluminum die casting	31a	Bearing	Ball bearing
11	Motor body	Aluminum die casting	31b	Bearing	Ball bearing
13	Pump body	NBR	33	Motor protector	
14	Impeller	High chrome alloy	34	Mechanical seal	Sic-Sic/Carbon-Sic
16a	Plate	NBR	38	Shaft sleeve	
16b	Inlet plate	Steel	47	Cable	

*Specifications can be changed without notice*

**Solidpump Europe SIA**

Uriekstes iela 14a  
 Rīga, LV-1005  
 LATVIA

Tel.: + 371 66968996  
 E-mail: info@solidpump.com  
 www.solidpump.com

Ver. 27.07.2023

**SOLIDPUMP EUROPE SIA**