

# PUMP PERFORMANCE CURVES

TYPE: SUBMERSIBLE DRAINAGE PUMP

MODEL: 150MH22

FREQUENCY: 50Hz

## STANDARD SPECIFICATIONS

DISCHARGE BORE

150 mm

HEAD

Max: 50 m

Rated: 37 m

CAPACITY

Max: 3.33 m<sup>3</sup>/min

Rated: 2.0 m<sup>3</sup>/min

MOTOR OUTPUT

22 kW

PHASE x VOLTAGE

3 Øx 380/400V

CURRENT

41.5 A

POLES/REVOLUTION

2 P/ S.S.2850 min<sup>-1</sup>

STARTING METHOD

Star-Delta start

INSULATION CLASS

F/H

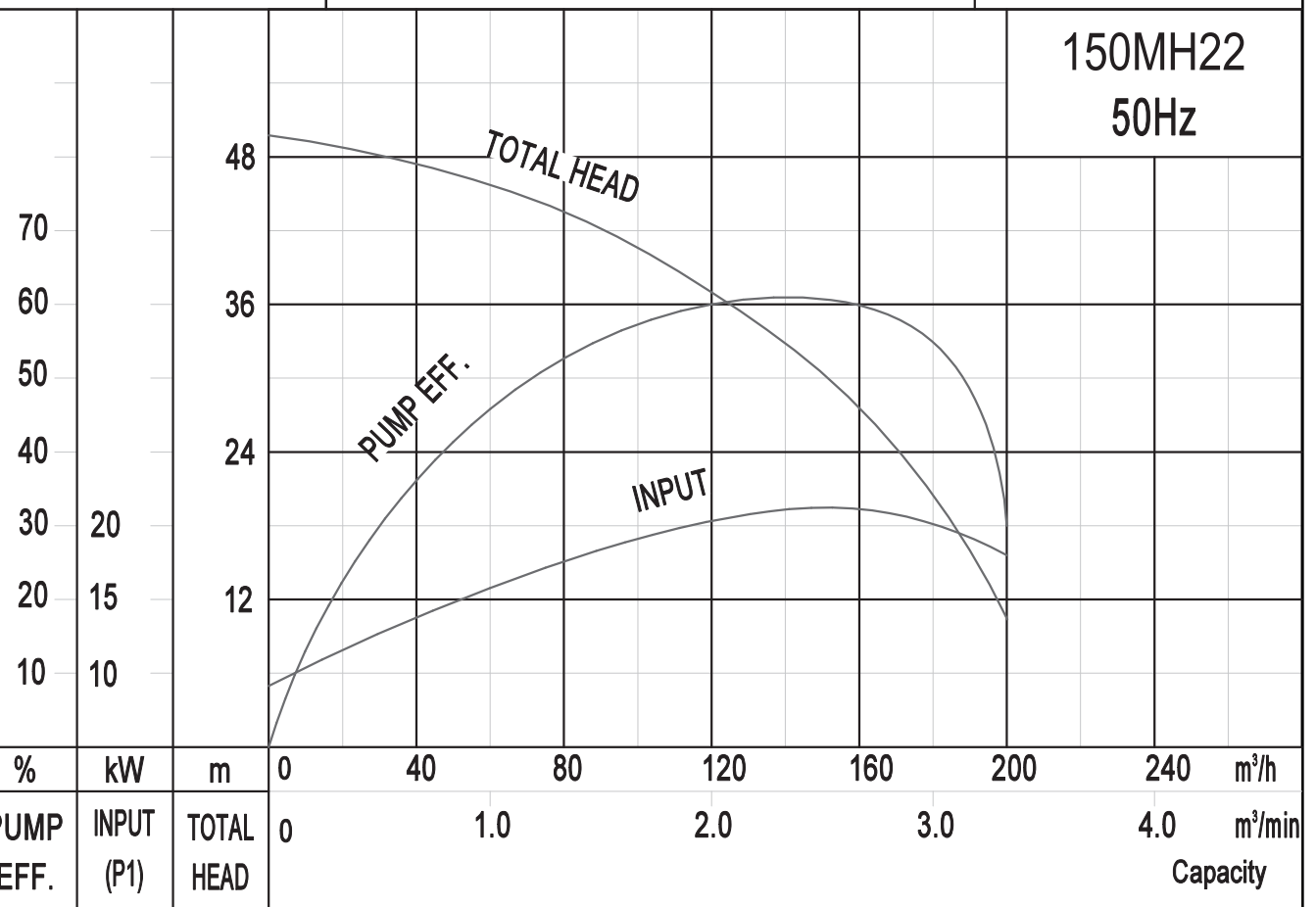

**SOLIDPUMP EUROPE SIA**

DIMENSION DRAWING  
TYPE: **SUBMERSIBLE DRAINAGE PUMP**

MODEL: 150MH22

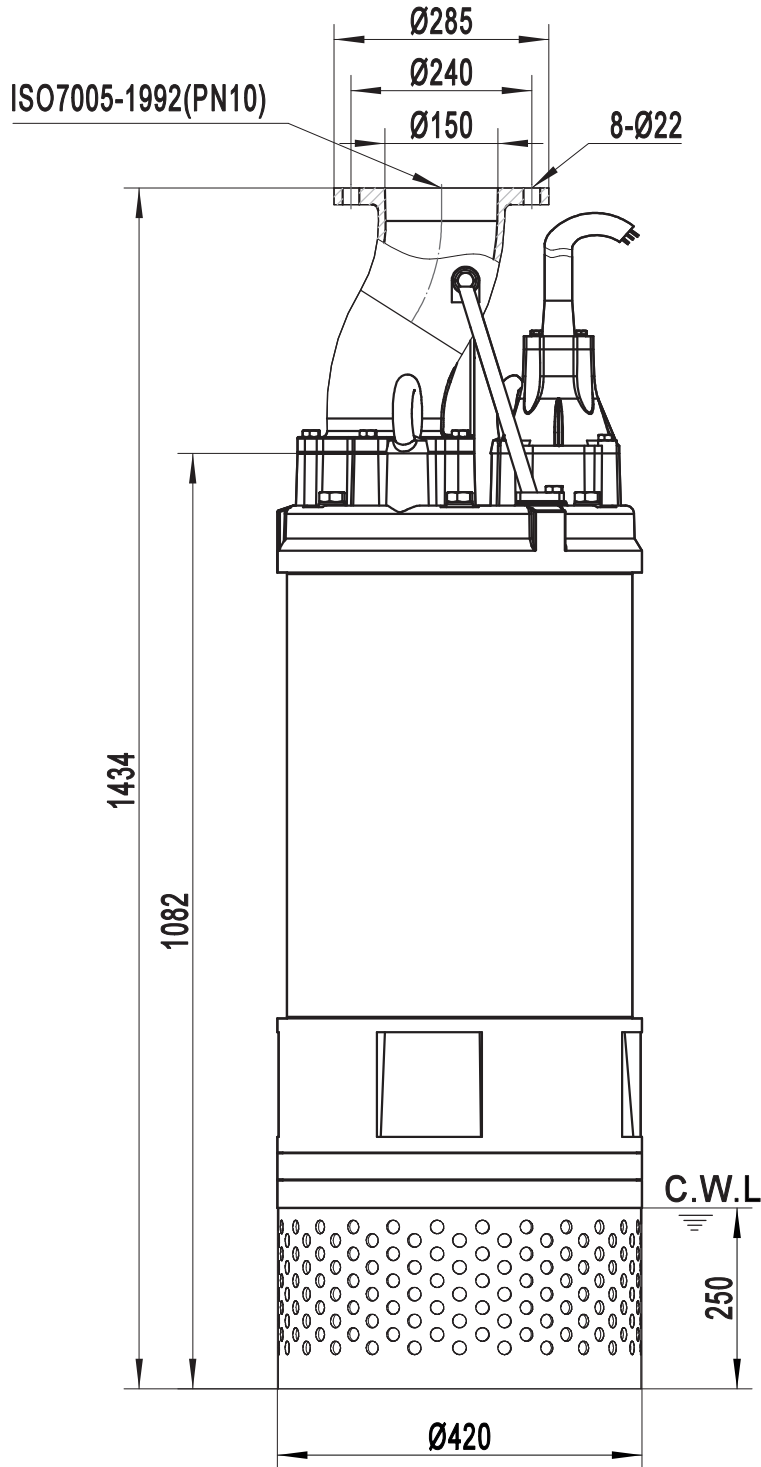

Model	N.W(kg)
150MH22	385

C.W.L.:Continuous Running Water Level.

**SOLIDPUMP EUROPE SIA**

# DIMENSION DRAWING

## TYPE: SUBMERSIBLE DRAINAGE PUMP

MODEL: 150MH22

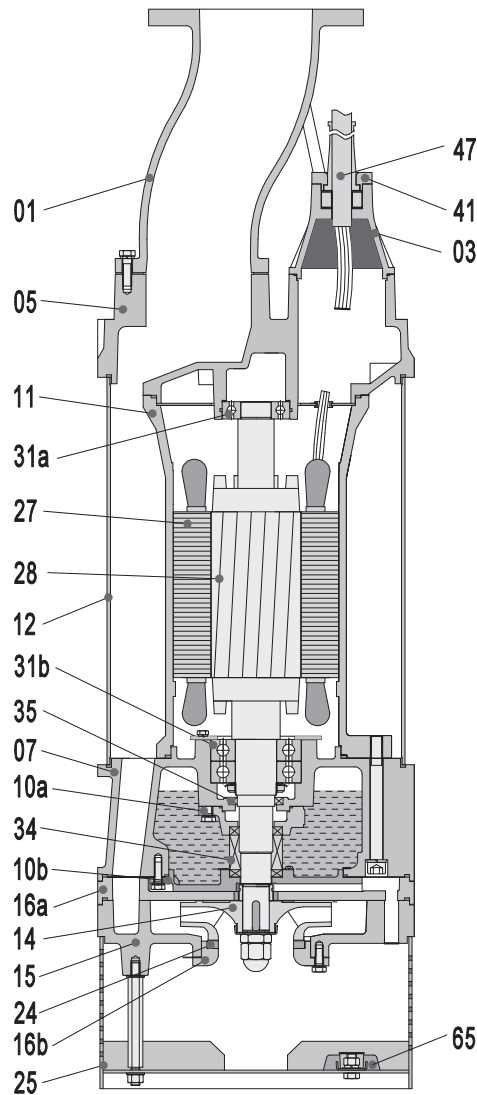

Item No.	Part name	Material	Item No.	Part name	Material
01	Hose coupling	Ductile iron	24	Neck ring	High chrome alloy
03	Terminal box	Cast iron	25	Strainer	AISI304SS
05	Upper cover	Cast iron	27	Stator	
07	Bearing house	Cast iron	28	Rotor	Shaft:AISI420SS
10a	Seal bracket	Cast iron	31a	Bearing	Ball bearing
10b	Seal bracket	Cast iron	31b	Bearing	Ball bearing
11	Motor body	Cast iron	34	Mechanical seal	Tc-Sic/Sic-Sic
12	Outer casing	Steel	35	Oil seal	
14	Impeller	High chrome alloy	41	Cable fixing plate	Cast iron
15	Diffuser	Ductile iron	47	Cable	
16a	Inlet plate	Ductile iron	65	Cathodic protection plate	AL
16b	Inlet plate	Cast iron			

*Specifications can be changed without notice*

### Solidpump Europe SIA

Uriekstes iela 14a  
Rīga, LV-1005  
LATVIA

Tel.: + 371 66968996  
E-mail: info@solidpump.com  
www.solidpump.com

Ver. 21.11.2022

**SOLIDPUMP EUROPE SIA**