

# PUMP PERFORMANCE CURVES

TYPE: SUBMERSIBLE SLURRY PUMP

MODEL: 200TBS37

FREQUENCY: 50Hz

## STANDARD SPECIFICATIONS

DISCHARGE BORE	200 mm	
HEAD	Max: 39 m	Rated: 32 m
CAPACITY	Max: 6.5 m <sup>3</sup> /min	Rated: 3.33 m <sup>3</sup> /min
MOTOR OUTPUT	37 kW	
PHASE x VOLTAGE	3 Øx 380/400V	
CURRENT	69.8 A	
POLES/REVOLUTION	4 P/ S.S.1450 min <sup>-1</sup>	
STARTING METHOD	Star-Delta start	
INSULATION CLASS	F	

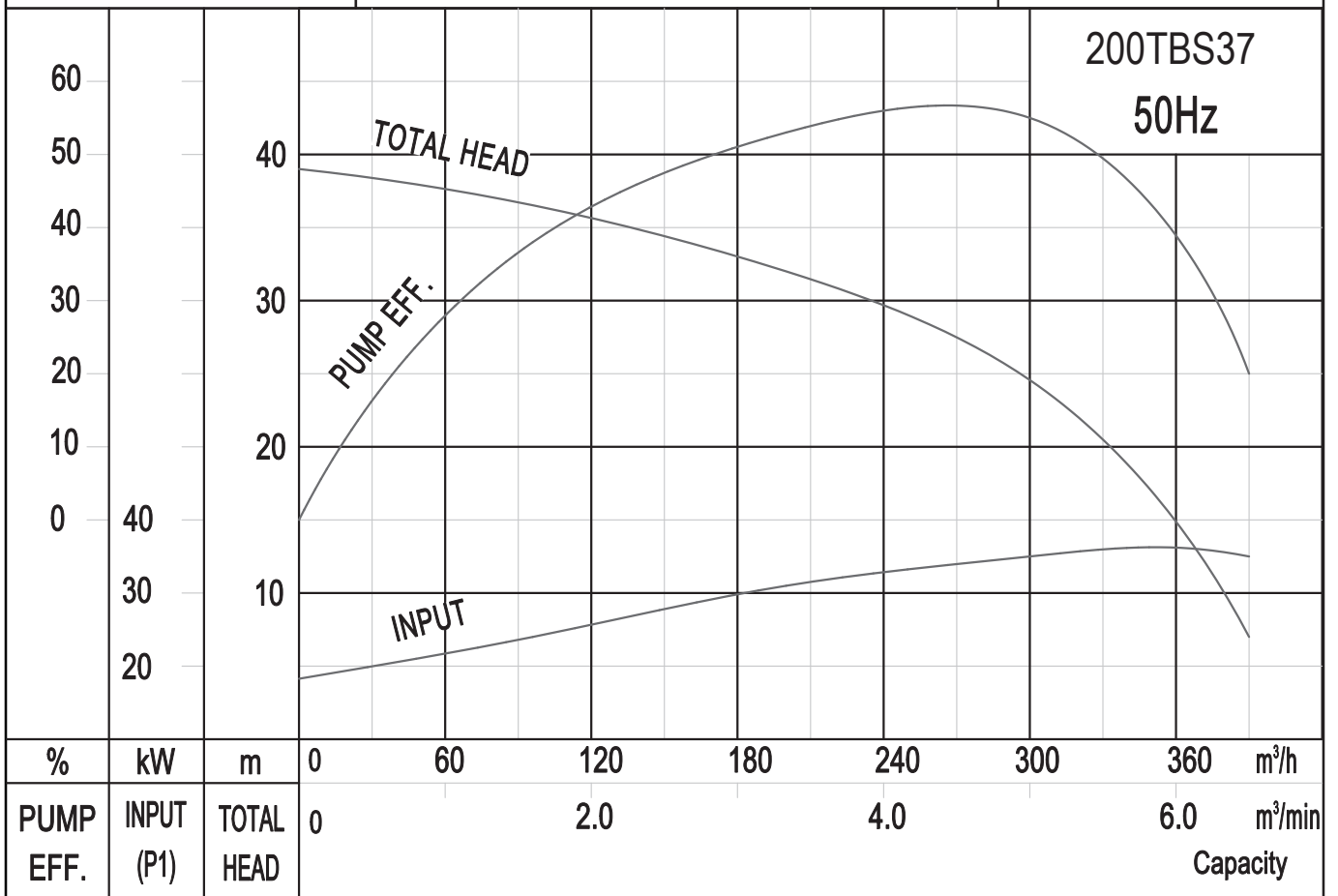

**SOLIDPUMP EUROPE SIA**

DIMENSION DRAWING  
TYPE: **SUBMERSIBLE SLURRY PUMP**

MODEL: 200TBS37

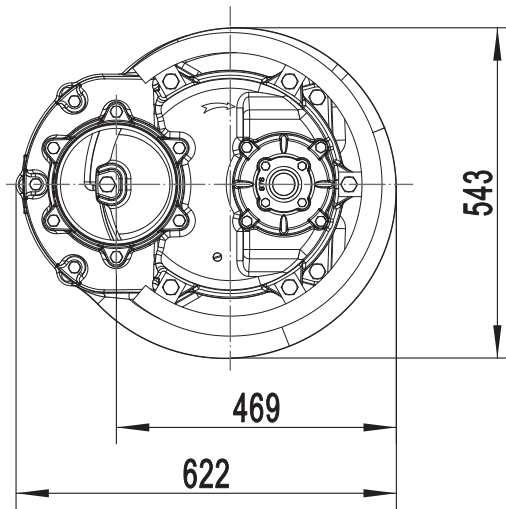

Model	N.W(kg)
200TBS37	535

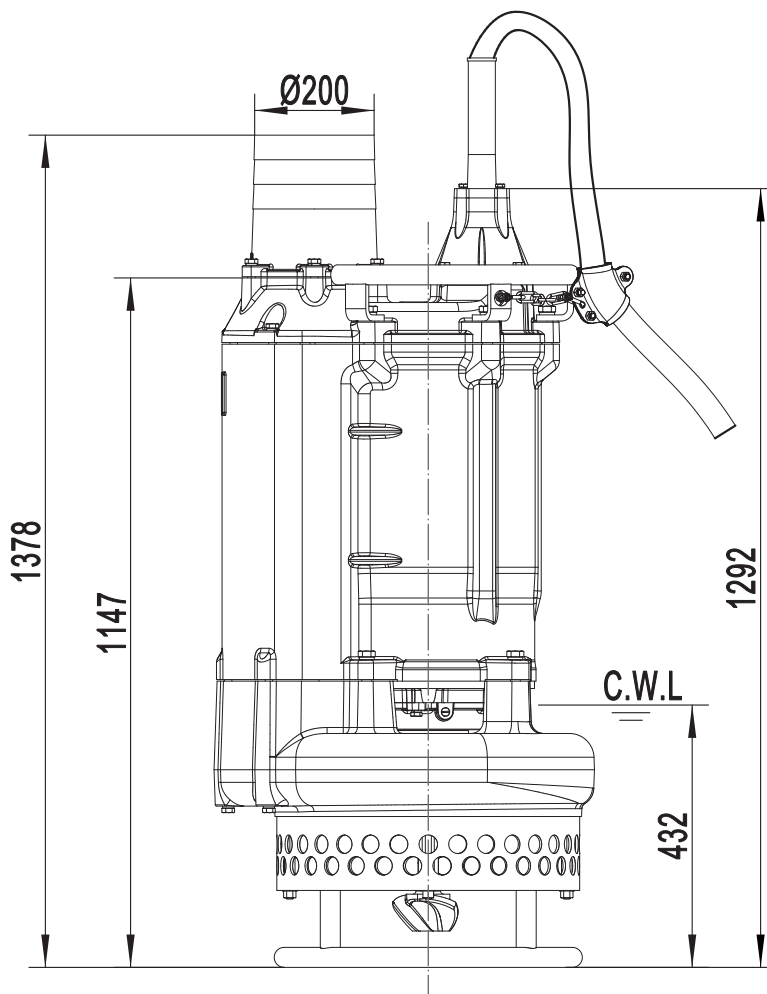

C.W.L.:Continuous Running Water Level.

**SOLIDPUMP EUROPE SIA**

DIMENSION DRAWING  
 TYPE: **SUBMERSIBLE SLURRY PUMP**

MODEL: 200TBS37

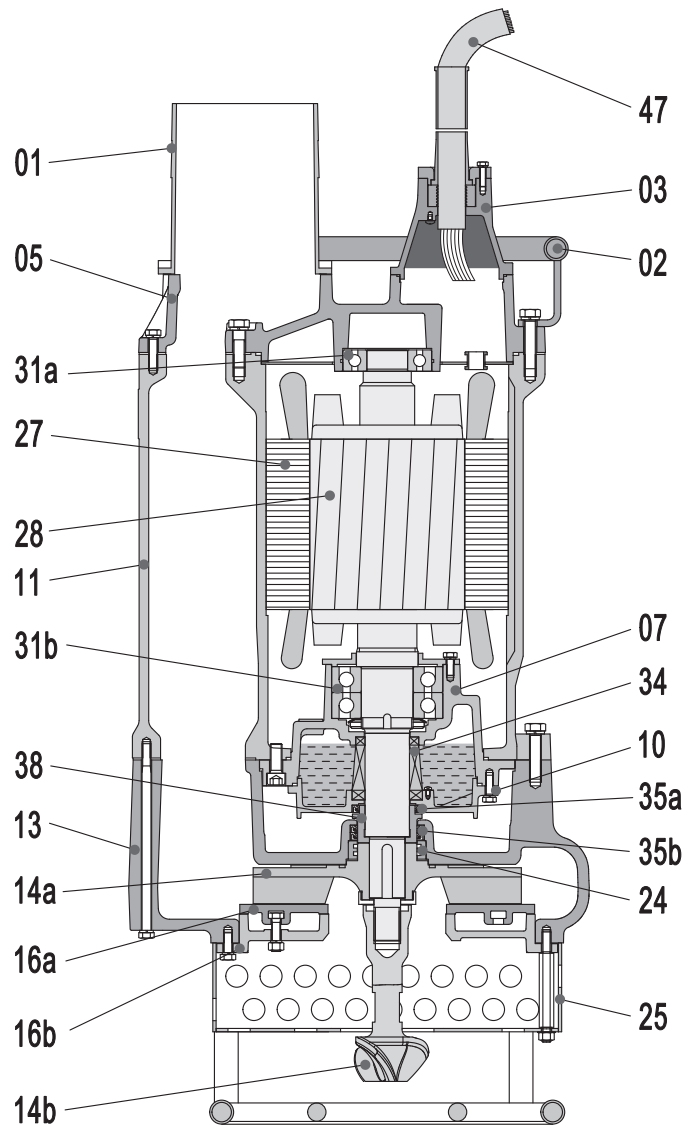

Item No.	Part name	Material	Item No.	Part name	Material
01	Hose coupling	Cast iron	24	Neck ring	AISI420SS
02	Handle	Steel	25	Strainer	Steel
05	Upper cover	Cast iron	27	Stator	
07	Bearing house	Cast iron	28	Rotor	Shaft:AISI420SS
10	Seal house	Cast iron	31a	Bearing	Ball bearing
11	Motor body	Cast iron	31b	Bearing	Angular contact bearing
13	Pump body	Cast iron	34	Mechanical seal	Sic-Sic/Sic-Sic
14a	Impeller	High chrome alloy	35a	Oil seal	
14b	Agitator	High chrome alloy	35b	Oil seal	
16a	Inlet plate	High chrome alloy	38	Shaft sleeve	AISI420SS
16b	Inlet plate	Cast iron	47	Cable	

*Specifications can be changed without notice*

**Solidpump Europe SIA**

Uriekstes iela 14a  
 Rīga, LV-1005  
 LATVIA

Tel.: + 371 66968996  
 E-mail: info@solidpump.com  
 www.solidpump.com

Ver. 21.11.2022

**SOLIDPUMP EUROPE SIA**