

# PUMP PERFORMANCE CURVES

TYPE: SUBMERSIBLE DRAINAGE PUMP

MODEL: 50TSAE0.48

FREQUENCY: 50Hz

## STANDARD SPECIFICATIONS

DISCHARGE BORE

50 mm

HEAD

Max: 11.5 m

Rated: 8 m

CAPACITY

Max: 0.23 m<sup>3</sup>/min

Rated: 0.12 m<sup>3</sup>/min

MOTOR OUTPUT

0.48 kW

PHASE x VOLTAGE

1 Øx 230 V

CURRENT

3.0 A

POLES/REVOLUTION

2 P/ S.S.2850 min<sup>-1</sup>

STARTING METHOD

Direct-on-line start

INSULATION CLASS

F

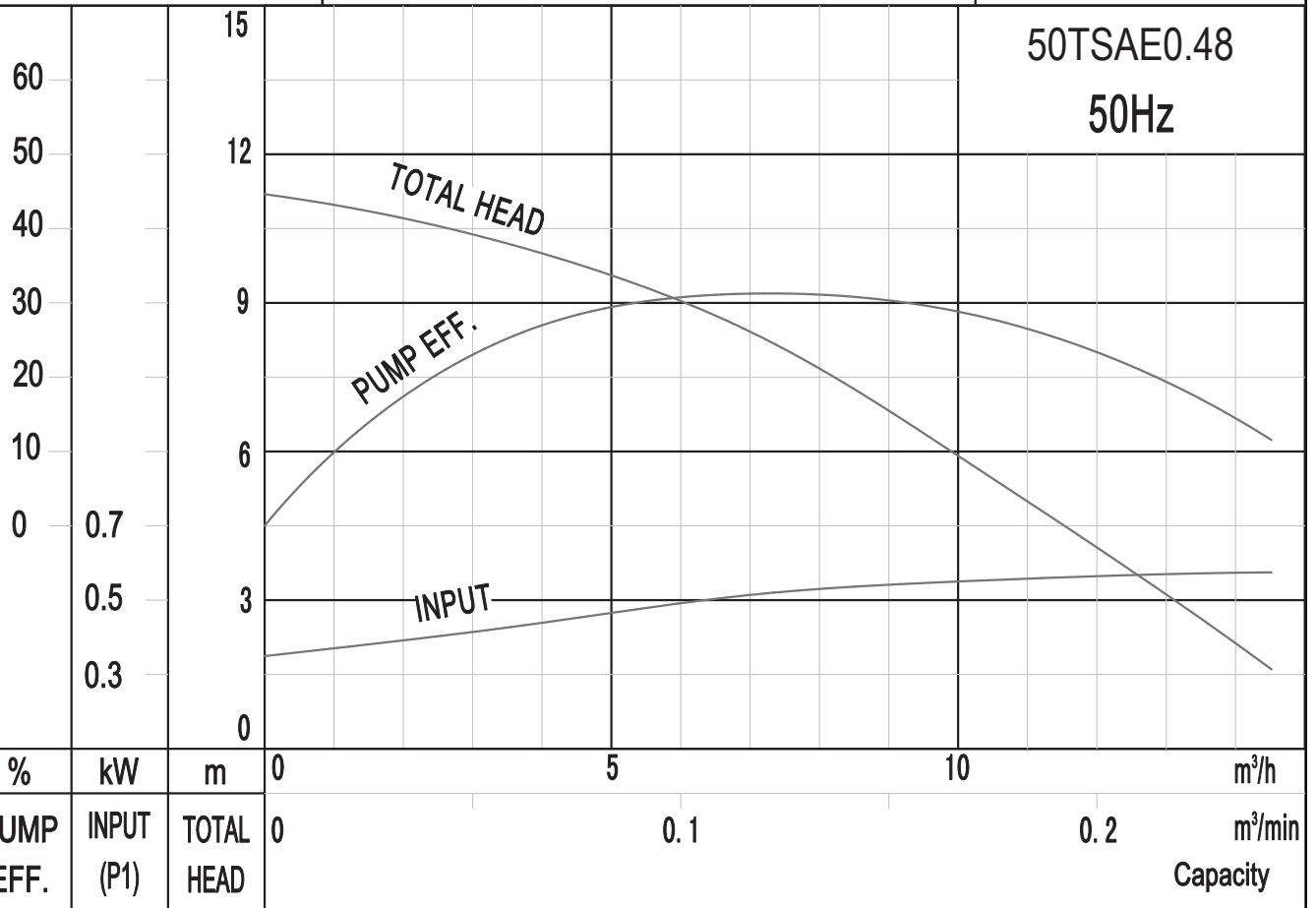

**SOLIDPUMP EUROPE SIA**

DIMENSION DRAWING

TYPE: **SUBMERSIBLE DRAINAGE PUMP**

MODEL: 50TSAE0.48

Model	N.W(kg)
50TSAE0.48	11.8

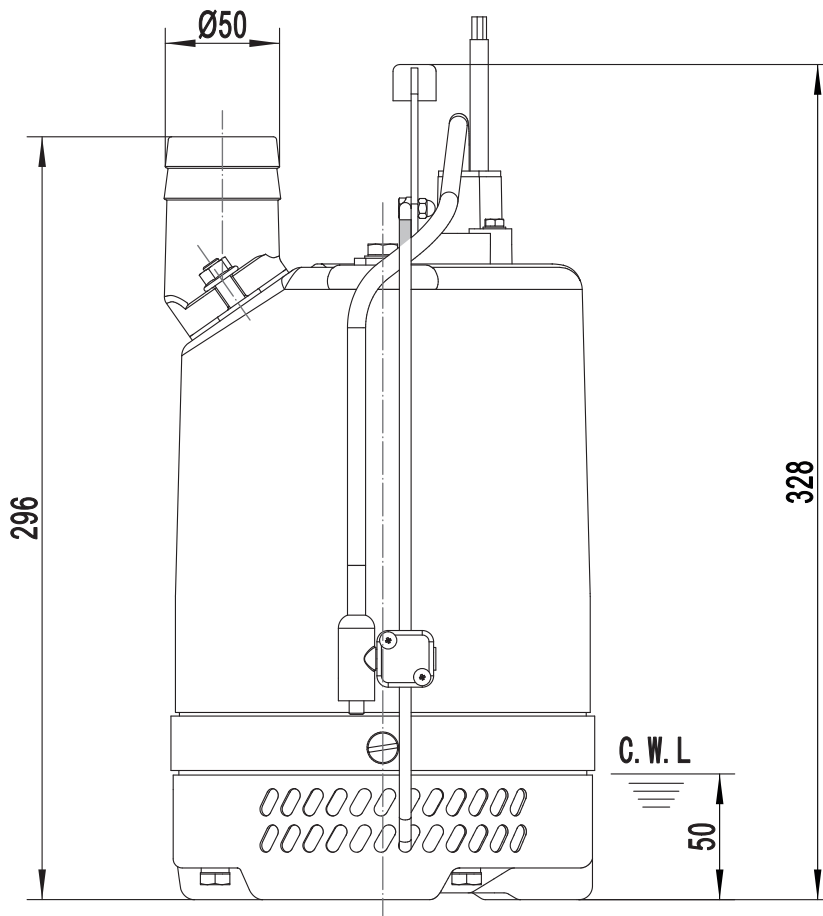
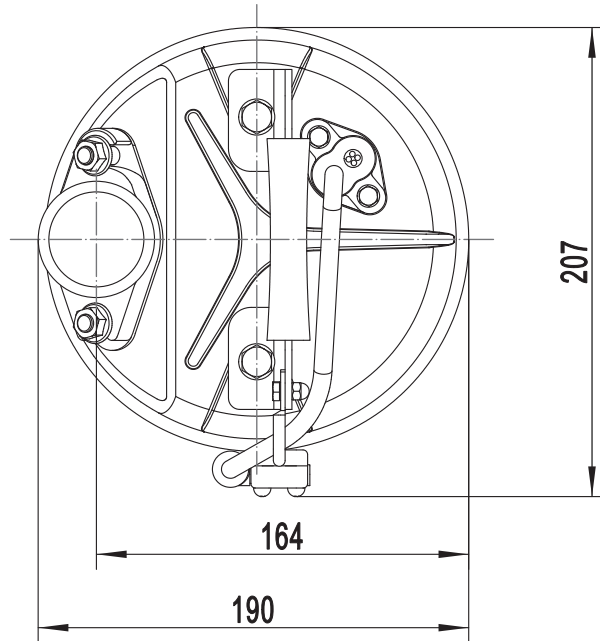

C.W.L.:Continuous Running Water Level.

**SOLIDPUMP EUROPE SIA**

# DIMENSION DRAWING

## TYPE: SUBMERSIBLE DRAINAGE PUMP

MODEL: 50TSAE0.48

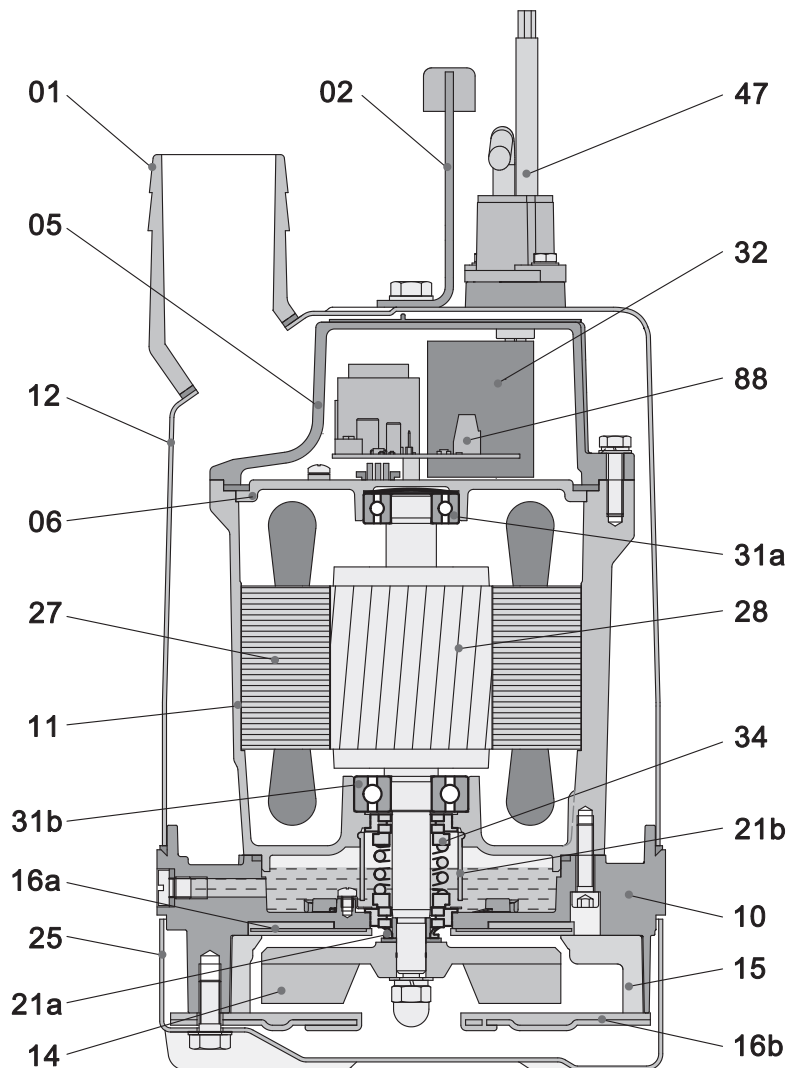

Item No.	Part name	Material	Item No.	Part name	Material
01	Hose coupling	Aluminum die casting	21a	Oil riser	NBR
02	Handle	Rubber & steel	21b	Sand guard	LDPE
05	Upper cover	Aluminum die casting	25	Strainer	Steel
06	Up-Bearing house	Cast iron	27	Stator	
10	Seal house	Aluminum die casting	28	Rotor	Shaft:AISI420SS
11	Motor body	Aluminum die casting	31a	Bearing	Ball bearing
12	Outer casing	Steel	31b	Bearing	Ball bearing
14	Impeller	Ductile iron	32	Capacitor	
15	Diffuser	NBR	34	Mechanical seal	Ceramic-Sic/Carbon-Ceramic
16a	Plate	NBR & Steel	47	Cable	H07RNF
16b	Intel plate	NBR & Steel	88	Controller block	

*Specifications can be changed without notice*

### Solidpump Europe SIA

Uriekstes iela 14a  
Rīga, LV-1005  
LATVIA

Tel.: + 371 66968996  
E-mail: info@solidpump.com  
www.solidpump.com

Ver. 21.11.2022

**SOLIDPUMP EUROPE SIA**