

PUMP PERFORMANCE CURVES

TYPE: SUBMERSIBLE DRAINAGE PUMP		MODEL: 80TBAME1.5	FREQUENCY: 50Hz
STANDARD SPECIFICATIONS			
DISCHARGE BORE	80 mm		
HEAD	Max: 20 m	Rated: 15 m	
CAPACITY	Max: 29 m ³ /h	Rated: 12 m ³ /h	
SOLIDS DIA	8.5 mm		
MOTOR OUTPUT	1.5 kW		
PHASE x VOLTAGE	1 Øx 230 V		
CURRENT	10.0 A		
POLES/REVOLUTION	2 P/ S.S.2850 min ⁻¹		
STARTING METHOD	Direct on line		
INSULATION CLASS	F		

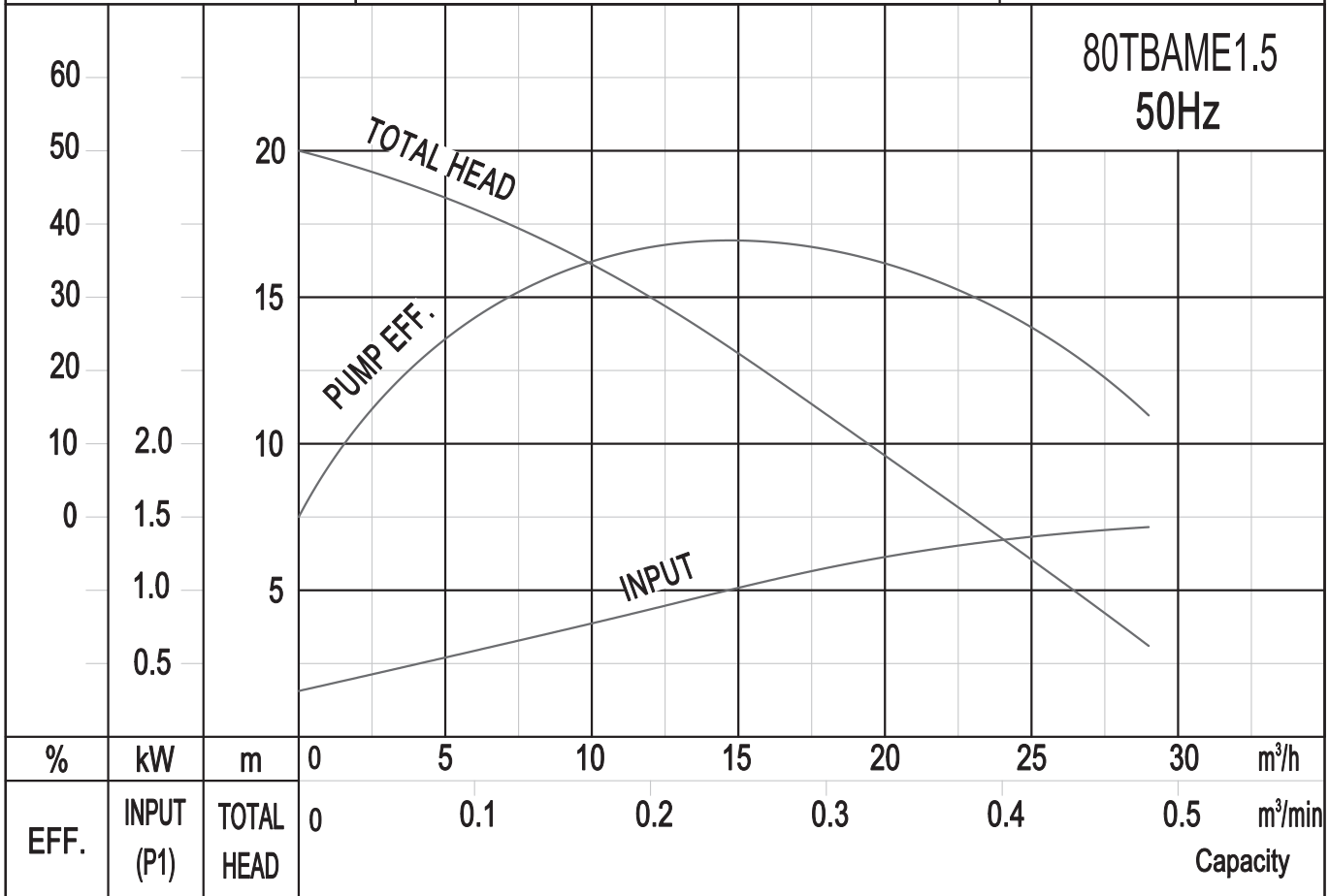

SOLIDPUMP EUROPE SIA

SECTIONAL DRAWING
TYPE: **SUBMERSIBLE DRAINAGE PUMP**

MODEL: 80TBAME1.5

Model	N.W(kg)
80TBAME1.5	27

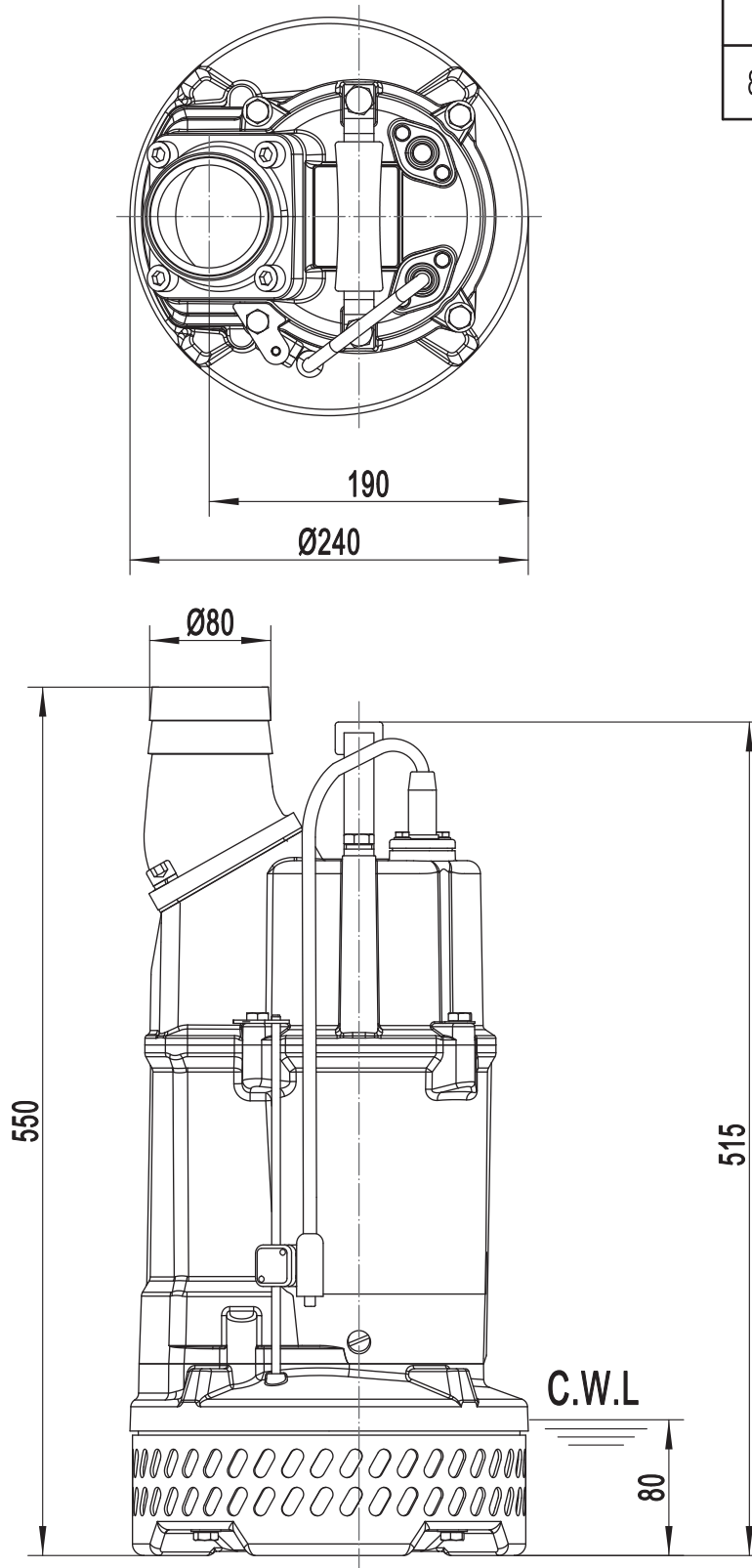

C.W.L.:Continuous Running Water Level.

SOLIDPUMP EUROPE SIA

SECTIONAL DRAWING
TYPE: **SUBMERSIBLE DRAINAGE PUMP**

MODEL: 80TBAME1.5

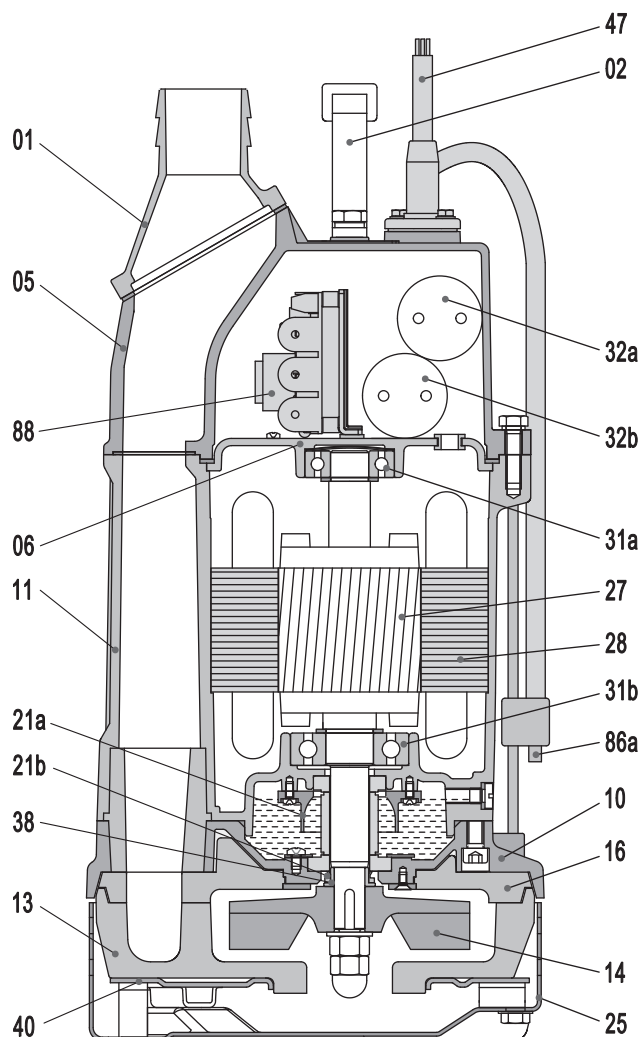

Item No.	Part name	Material	Item No.	Part name	Material
01	Hose coupling	Aluminum die casting	28	Rotor	Shaft:Stainless steel
02	Handle	Rubber & AISI304SS	31a	Bearing	Ball bearing
05	Upper cover	Aluminum die casting	31b	Bearing	Ball bearing
06	Up-Bearing house	Cast iron	32a	Starting capacitor	
10	Seal house	Aluminum die casting	32b	Capacitor	
11	Motor body	Aluminum die casting	34	Mechanical seal	Sic-Sic/Carbon-Sic
13	Pump body	NBR	38	Shaft sleeve	
14	Impeller	High chrome alloy	40	Clamping plate	Steel
16	Plate	NBR	47	Cable	
21a	Oil riser	NBR	86a	Water level sensor	
21b	Sand guard	PA66+GF30	88	Controller block	
27	Stator				

Specifications can be changed without notice

Solidpump Europe SIA

Uriekstes iela 14a
Rīga, LV-1005
LATVIA

Tel.: + 371 66968996
E-mail: info@solidpump.com
www.solidpump.com

ver. 12.12.2024

SOLIDPUMP EUROPE SIA