

PUMP PERFORMANCE CURVES

TYPE: INTELLGENT SUBMERSIBLE DRAINAGE PUMP

MODEL: 50TBZE2.2

FREQUENCY: 50Hz

STANDARD SPECIFICATIONS

DISCHARGE BORE

50 mm

HEAD

Max: 26 m

Rated: 20 m

CAPACITY

Max: 0.55 m³/min

Rated: 0.30 m³/min

MOTOR OUTPUT

2.2 kW

PHASE x VOLTAGE

3 Øx 400 V

CURRENT

5.0 A

POLES/REVOLUTION

2 P/ S.S.2850 min⁻¹

STARTING METHOD

Direct-on-line start

INSULATION CLASS

F

60

50

40

30

20

10

0

2.8

2.4

2.0

%

kW

m

0

5

10

15

20

25

30

m³/h

PUMP
EFF.

INPUT
(P1)

TOTAL
HEAD

0

0.25

0.5

m³/min

Capacity

50TBZE2.2
50Hz

TOTAL HEAD

PUMP EFF.

INPUT

24

18

12

6

SOLIDPUMP EUROPE SIA

DIMENSION DRAWING

TYPE: **SUBMERSIBLE DRAINAGE PUMP**

MODEL: 50TBZE2.2

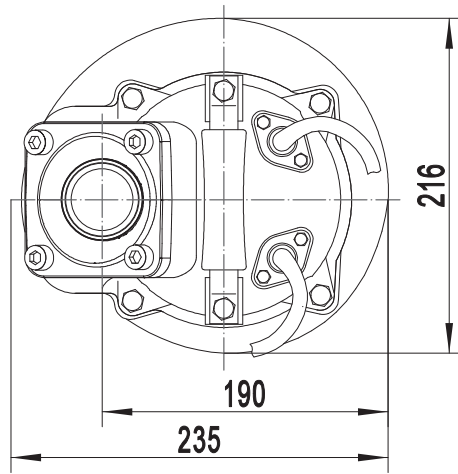

Model	N.W(kg)
50TBZE2.2	44

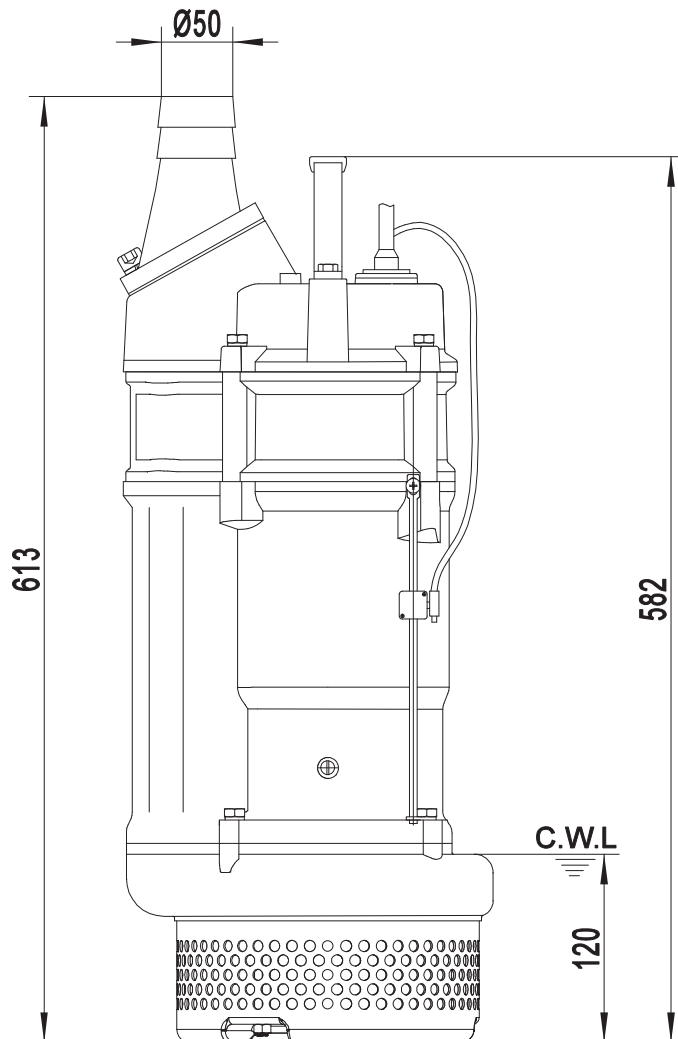

C.W.L:Continuous Running Water Level.

SOLIDPUMP EUROPE SIA

DIMENSION DRAWING

TYPE: SUBMERSIBLE DRAINAGE PUMP

MODEL: 50TBZE2.2

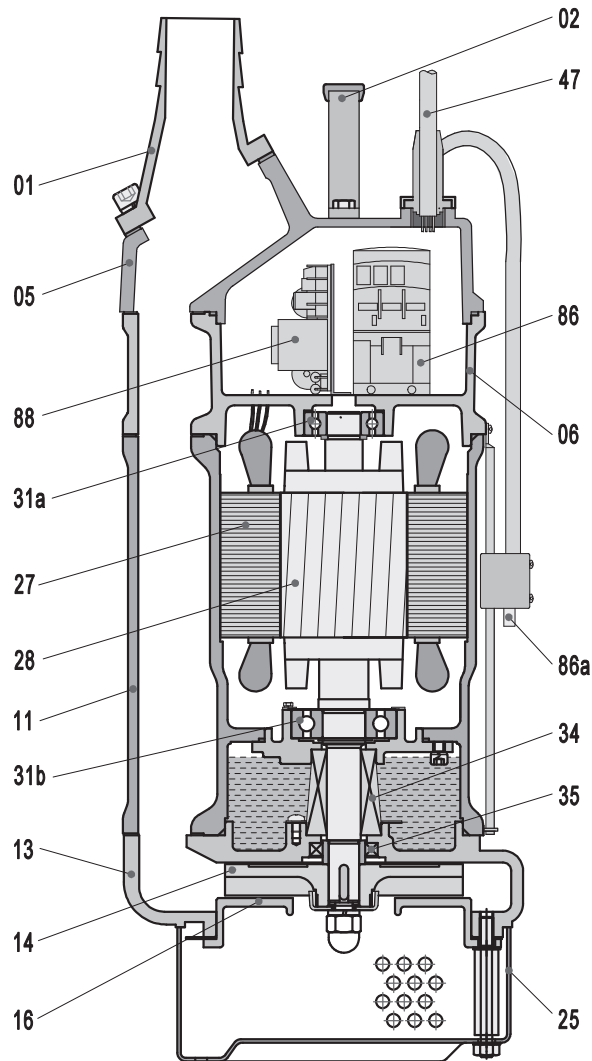

Item No.	Part name	Material	Item No.	Part name	Material
01	Hose coupling	Cast iron	28	Rotor	Shaft:AISI420SS
02	Handle	Rubber&steel	31a	Bearing	Ball bearing
05	Upper cover	Cast iron	31b	Bearing	Ball bearing
06	Upper support	Cast iron	34	Mechanical seal	Sic-Sic/Carbon-Sic
11	Motor body	Cast iron	35	Oil seal	
13	Pump body	Cast iron	47	Cable	
14	Impeller	High chrome alloy	86	AC Contactor	
16	Inlet plate	Ductile iron	86a	Water level sensor	
25	Strainer	Steel	88	Controller block	
27	Stator				

Specifications can be changed without notice

Solidpump Europe SIA

Uriekstes iela 14a
Rīga, LV-1005
LATVIA

Tel.: + 371 66968996
E-mail: info@solidpump.com
www.solidpump.com

Ver. 21.11.2022

SOLIDPUMP EUROPE SIA