

# PUMP PERFORMANCE CURVES

TYPE: SUBMERSIBLE DRAINAGE PUMP

MODEL: 200TBL9

FREQUENCY: 50Hz

## STANDARD SPECIFICATIONS

DISCHARGE BORE

200 mm

HEAD

Max: 15 m

Rated: 11 m

CAPACITY

Max: 5.5 m<sup>3</sup>/min

Rated: 3.0 m<sup>3</sup>/min

MOTOR OUTPUT

9.0 kW

PHASE x VOLTAGE

3 Øx 400 V

CURRENT

19.5 A

POLES/REVOLUTION

4 P/ S.S.1450 min<sup>-1</sup>

STARTING METHOD

Direct-on-line start

INSULATION CLASS

F

60  
50  
40  
30  
20  
10  
0  
11  
8.0  
5.0

16  
12  
8  
4

200TBL9  
50Hz

PUMP EFF.

TOTAL HEAD

INPUT

%

kW

m

0

50

100

150

200

250

300

m<sup>3</sup>/h

PUMP  
EFF.

INPUT  
(P1)

TOTAL  
HEAD

0

1.0

2.0

3.0

4.0

5.0

m<sup>3</sup>/min

Capacity

SOLIDPUMP EUROPE SIA

SECTIONAL DRAWING  
TYPE: **SUBMERSIBLE DRAINAGE PUMP**

**MODEL: 200TBL9**

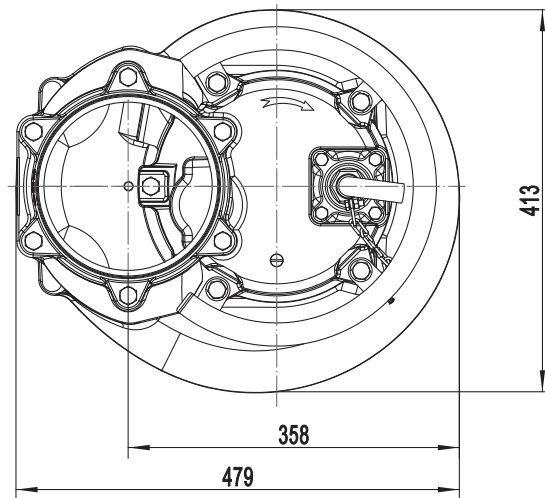

Model	N.W(kg)
200TBL9	175

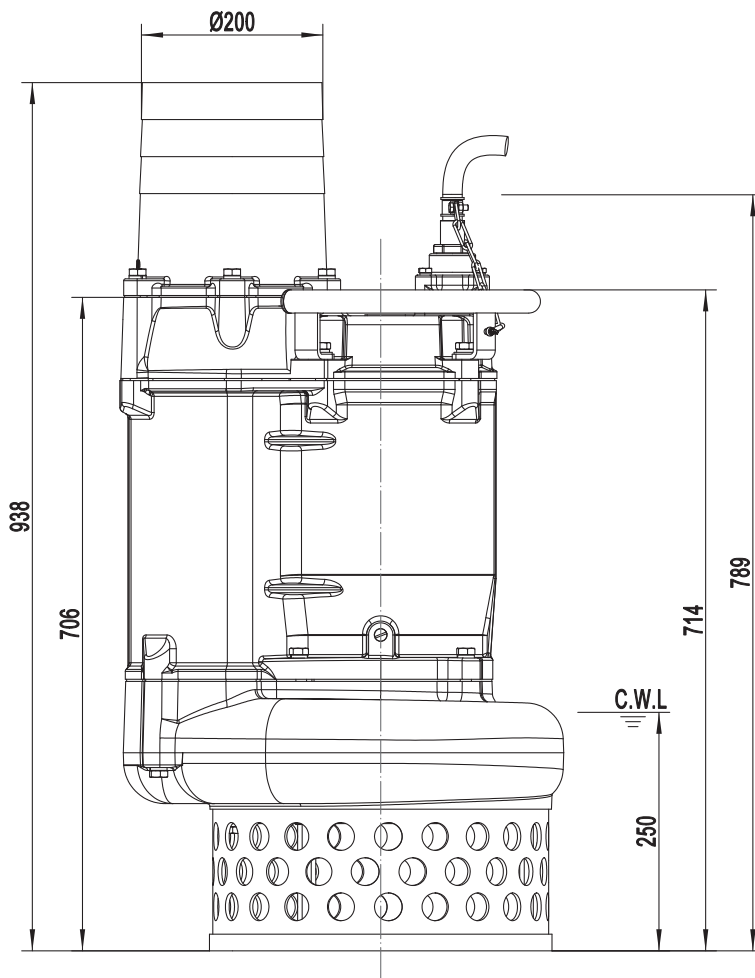

C.W.L:Continuous Running Water Level.

**SOLIDPUMP EUROPE SIA**

SECTIONAL DRAWING  
 TYPE: **SUBMERSIBLE DRAINAGE PUMP**

MODEL: TBL 9kW

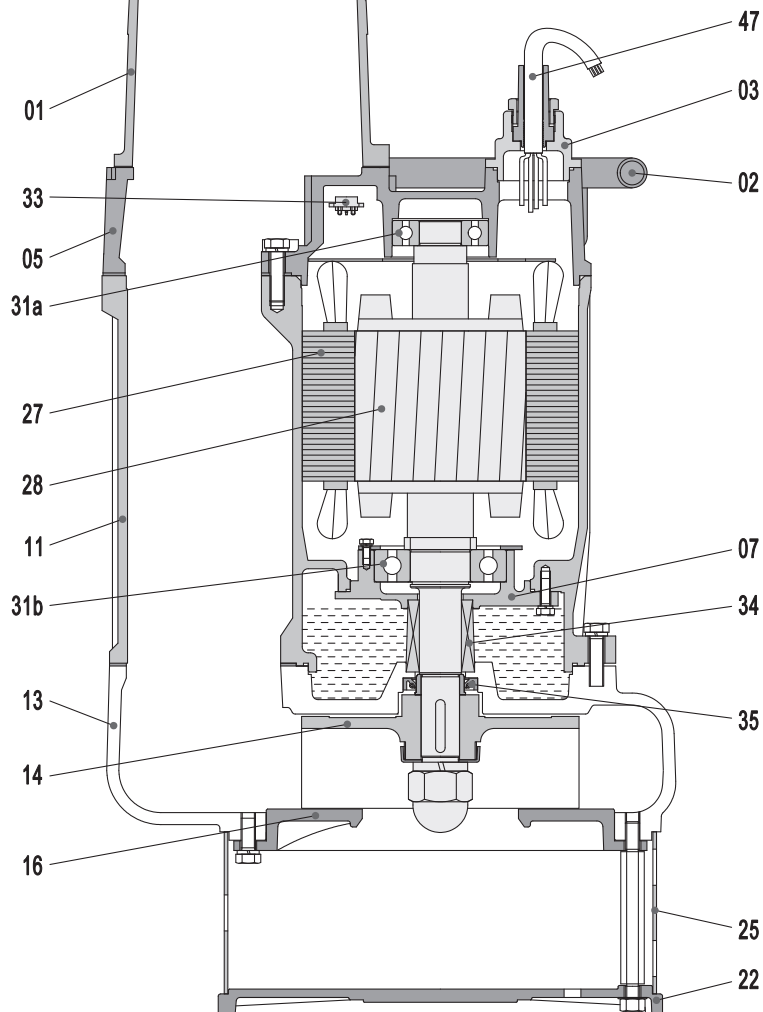

Item No.	Part name	Material	Item No.	Part name	Material
01	Hose coupling	Cast iron	25	Strainer	Steel
02	Handle	steel	27	Stator	
03	Terminal box	Cast iron	28	Rotor	Shaft:AISI420SS
05	Upper cover	Cast iron	31a	Bearing	Ball bearing
07	Bearing house	Cast iron	31b	Bearing	Ball bearing
11	Motor body	Cast iron	33	Motor protector	
13	Pump body	Cast iron	34	Mechanical seal	Sic-Sic/Sic-Sic
14	Impeller	Ductile iron	35	Oil seal	
16	Inlet plate	Ductile iron	47	Cable	
22	Seat assembly	Cast iron			

*Specifications can be changed without notice*

**Solidpump Europe SIA**  
 Uriekstes iela 14a  
 Rīga, LV-1005  
 LATVIA  
 Tel.: + 371 66968996  
 E-mail: info@solidpump.com  
 www.solidpump.com

Ver. 03.06.2024

**SOLIDPUMP EUROPE SIA**