

PUMP PERFORMANCE CURVES

TYPE: SUBMERSIBLE SLURRY PUMP

MODEL: 50PDM0.55

FREQUENCY: 50Hz

STANDARD SPECIFICATIONS

DISCHARGE BORE

50 mm

HEAD

Max: 13 m

Rated: 8 m

CAPACITY

Max: 0.22 m³/min

Rated: 0.13 m³/min

MOTOR OUTPUT

0.55 kW

PHASE x VOLTAGE

1 Øx 220 V

CURRENT

4.0 A

POLES/REVOLUTION

2 P/ S.S.2850 min⁻¹

STARTING METHOD

Direct-on-line start

INSULATION CLASS

F

60
50
40
30
20
10
0

0.7
0.5
0.3

12
9
6
3

TOTAL HEAD
PUMP EFF.
INPUT

50PDM0.55
50Hz

0 2 4 6 8 10 12 m³/h

PUMP EFF.	INPUT (P1)	TOTAL HEAD	0	0.05	0.1	0.15	0.2	m ³ /min
								Capacity

SOLIDPUMP EUROPE SIA

DIMENSION DRAWING
TYPE: **SUBMERSIBLE SLURRY PUMP**

MODEL: 50PDM0.55

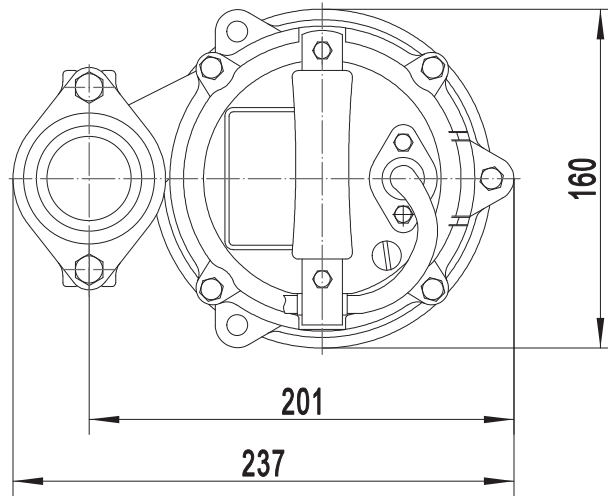

Model	N.W(kg)
50PDM0.55	15.2

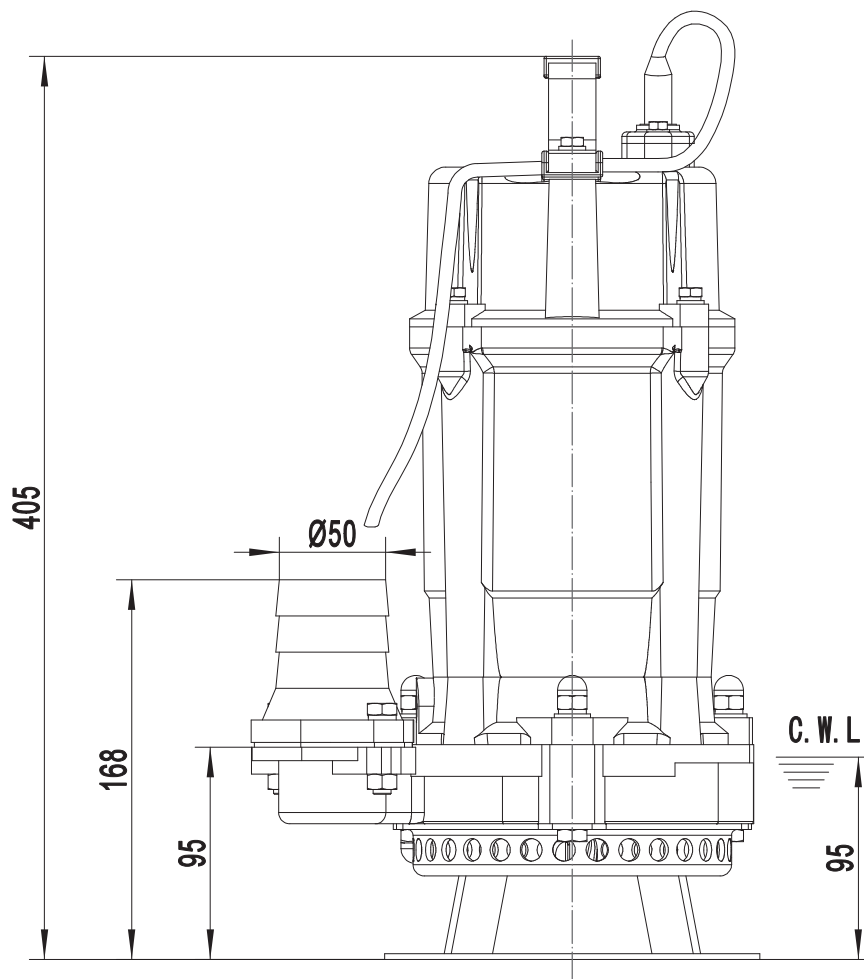

C.W.L.:Continuous Running Water Level.

SOLIDPUMP EUROPE SIA

DIMENSION DRAWING

TYPE: **SUBMERSIBLE SLURRY PUMP**

MODEL: 50PDM0.55

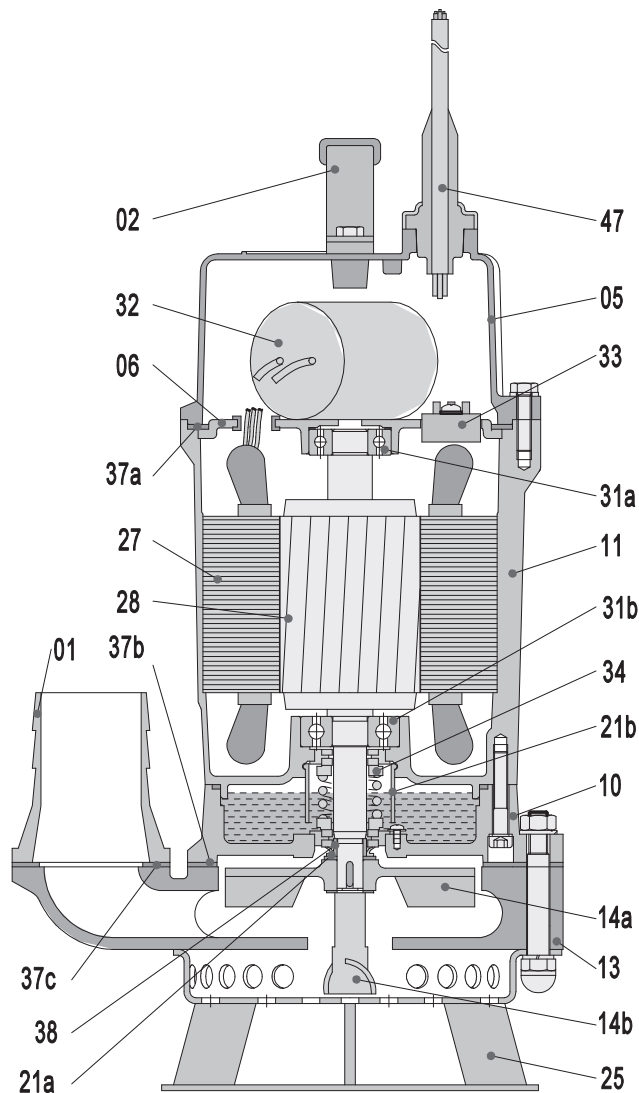

Item No.	Part name	Material	Item No.	Part name	Material
01	Hose coupling	Cast iron	27	Stator	
02	Handle	Rubber&steel	28	Rotor	Shaft:AISI420SS
05	Upper cover	Aluminum die casting	31a	Bearing	Ball bearing
06	Up-Bearing house	Cast iron	31b	Bearing	Ball bearing
10	Seal house	Cast iron	32	Capacitor	
11	Motor body	Aluminum die casting	33	Motor protector	
13	Pump body	Cast iron	34	Mechanical seal	Ceramic-Sic/Carbon-Ceramic
14a	Impeller	High chrome alloy	37a	Gasket	NBR
14b	Agitator	High chrome alloy	37b	Gasket	NBR
21a	Oil riser	NBR	37c	Gasket	NBR
21b	Sand guard	LDPE	38	Shaft sleeve	AISI420SS
25	Strainer	Steel	47	Cable	H07RN-F

Specifications can be changed without notice

Solidpump Europe SIA
 Uriekstes iela 14a
 Rīga, LV-1005
 LATVIA
 Tel.: + 371 66968996
 E-mail: info@solidpump.com
 www.solidpump.com

Ver. 21.11.2022

SOLIDPUMP EUROPE SIA