

PUMP PERFORMANCE CURVES

TYPE: AUTOMATIC SUBMERSIBLE
AGITATOR PUMP

MODEL: 80TBDE3.7

FREQUENCY: 50Hz

STANDARD SPECIFICATIONS

DISCHARGE BORE

80 mm

HEAD

Max: 30 m

Rated: 20 m

CAPACITY

Max: 1.0 m³/min

Rated: 0.5 m³/min

MOTOR OUTPUT

3.7 kW

PHASE x VOLTAGE

3 Øx 400 V

CURRENT

7.7 A

POLES/REVOLUTION

2 P/ S.S.2850 min⁻¹

STARTING METHOD

Direct-on-line start

INSULATION CLASS

F

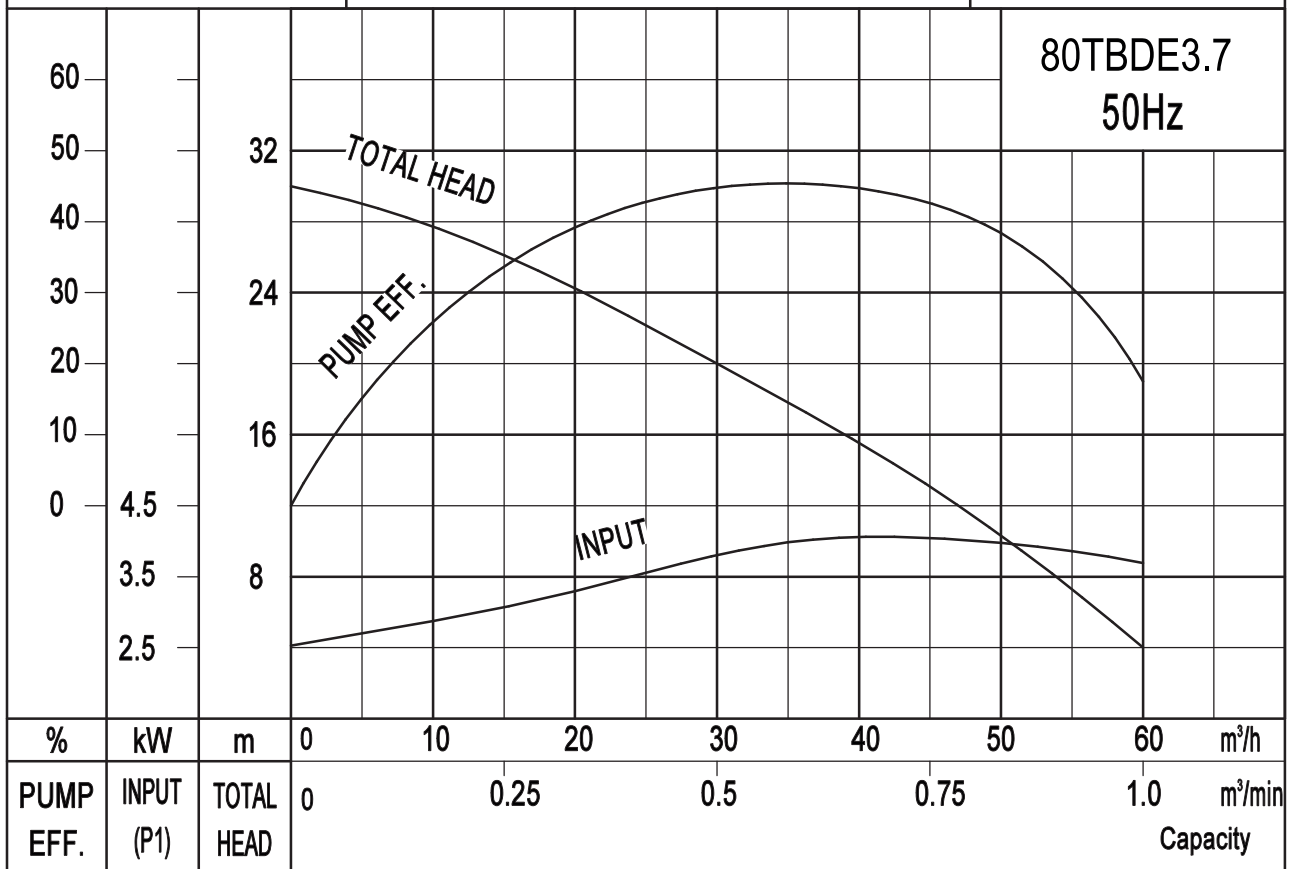

SOLIDPUMP EUROPE SIA

DIMENSION DRAWING

TYPE: AUTOMATIC SUBMERSIBLE AGITATOR PUMP

MODEL: 80TBDE3.7

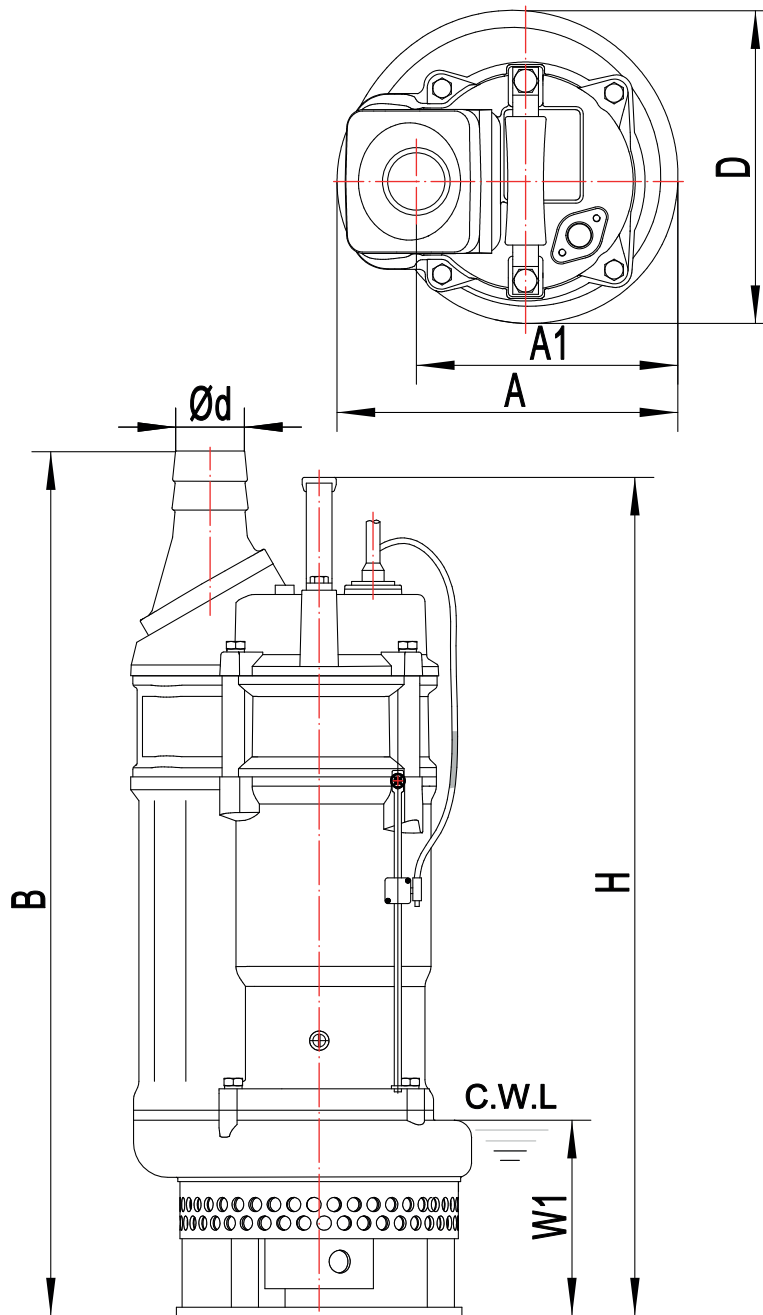

W1:Continuous running water level

Model (50Hz)	d	A	A1	B	D	H	W1	N.W
	mm	mm	mm	mm	mm	mm	mm	Kg
50TBDE1.5	50	235	173	629	216	594	135	43
50TBDE2.2	50	235	173	629	216	594	135	46
● 80TBDE3.7	80	283	208	714	252	720	165	72
100TBDE3.7	100	283	208	739	252	720	165	73

DIMENSION DRAWING

TYPE: AUTOMATIC SUBMERSIBLE AGITATOR PUMP

MODEL: 80TBDE3.7

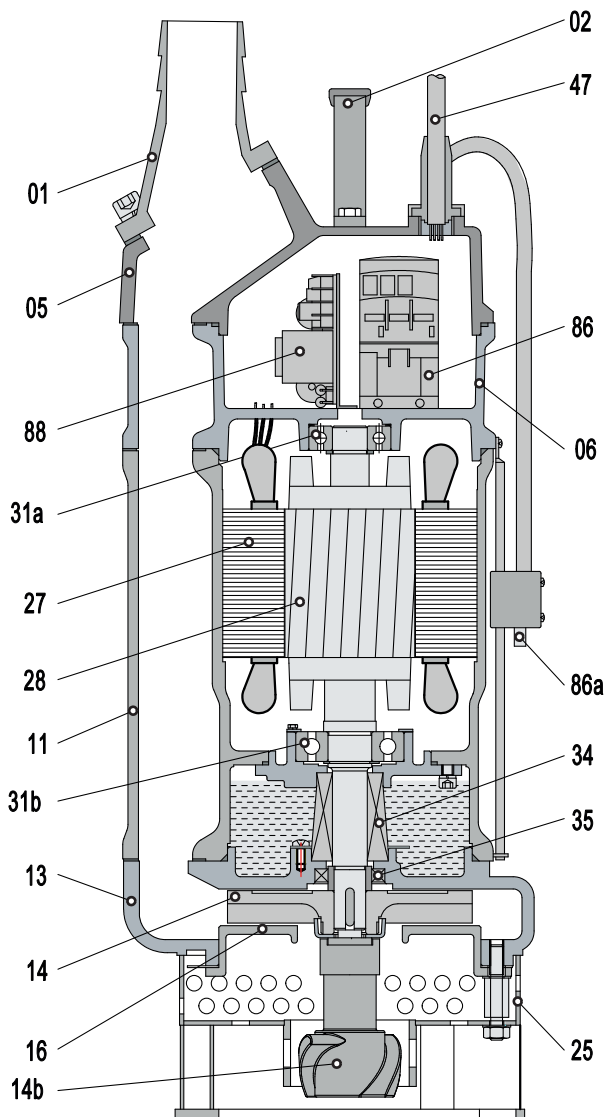

Item No.	Part name	Material	Item No.	Part name	Material
01	Hose coupling	Cast iron	28	Rotor	Shaft: AISI420SS
02	Handle	Rubber&steel	31a	Bearing	Ball bearing
05	Upper cover	Cast iron	31b	Bearing	Ball bearing
06	Upper support	Cast iron	34	Mechanical seal	Sic-Sic/Carbon-Sic(≤2.2kW) Sic-Sic/Sic-Sic(3.7kW)
11	Motor body	Cast iron	35	Oil seal	
13	Pump body	Cast iron	47	Cable	
14a	Impeller	High chrome alloy	86	AC Contactor	
14b	Agitator	High chrome alloy	86a	Water level sensor	
16	Inlet plate	Ductile iron	88	Controller block	
25	Strainer	Steel			
27	Stator				

Specifications can be changed without notice

Solidpump Europe SIA

Uriekstes iela 14a
Rīga, LV-1005
LATVIA

Tel.: + 371 66164228
E-mail: info@solidpump.com
www.solidpump.com

SOLIDPUMP EUROPE SIA