

PROFESSIONAL SUBMERSIBLE DRAINAGE, SAND AND SLURRY PUMPS

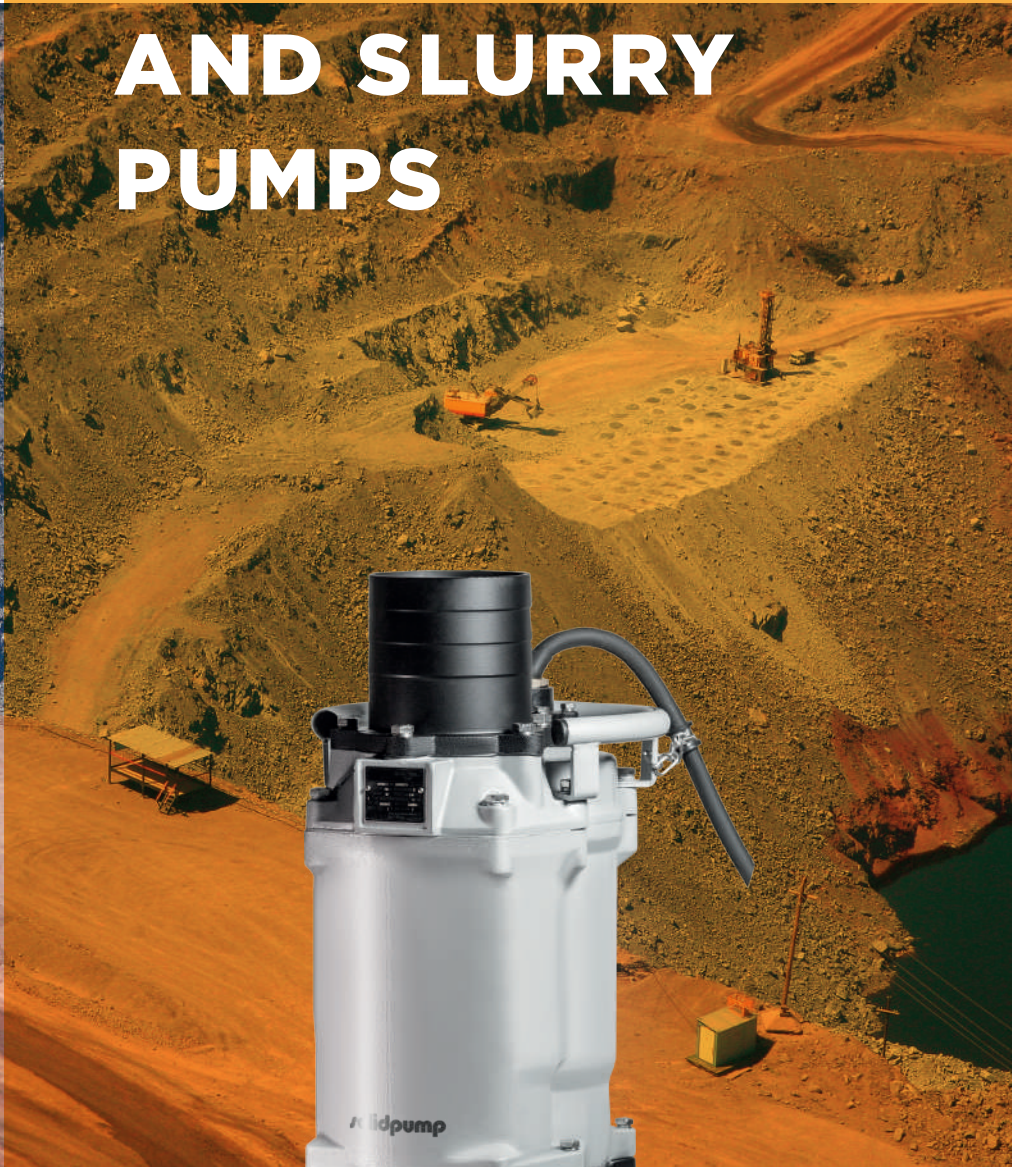

TBZ SUBMERSIBLE CONTRACTORS' DEWATERING PUMP



TBZ-series robust pumps are best suited for draining in civil engineering, but can be also used for general pumping purposes.

Motor and pump casing is made of rigid cast iron for long-lasting durability. Maximum submersion depth is greatly increased due to mechanical seal resistant to high pressure. Semi-open impeller made of high chrome alloy in combination with wear plate (ductile iron) achieves superior durability.

Effective motor cooling due to execution of discharge channel integrated into the motor housing. Space saving design due to a top outlet.

Discharge outlet from 50mm to 150mm, Motor from 1,5kW to 15kW. Hermetically sealed motors below 15kW are equipped with build-in thermal protection.

Technical Specifications

- Capacity: up to 160 m³/h
- Head: up to 57 meters
- Power: 1.5kW to 15kW
- Power supply: Three phase 400V ± 10%, 50Hz
- Insulation class: F
- Protection class: IP68
- Cable length: 20 m
- Water temperature: up to 40°C
- Max. water depth: 25 m

Application

- Construction sites
- Mining and industrial sites
- Drainage and contaminated water
- General pumping purposes

Optional Features

- Other voltages
- Other length of cable

Dimensions and Weight

Model (50Hz)	d	A	A1	B	D	H	W1	N.W.	G.W.	Packing dimension
	mm	mm	mm	mm	mm	mm	mm	kg	kg	mm
50TBZ1.5	50	235	173	535	216	505	120	36	40	610x265x265
80TBZ1.5	80	235	173	535	216	505	120	36	40	610x265x265
50TBZ2.2	50	235	173	535	216	505	120	39	43	610x265x265
80TBZ2.2	80	235	173	535	216	505	120	39	43	610x265x265
50TBZ3.7	50	283	208	628	252	629	150	63	68	710x320x295
80TBZ3.7	80	283	208	628	252	629	150	63	68	710x320x295
100TBZ3.7	100	283	208	642	252	629	150	63	68	710x320x295
80TBZ5.5	80	283	208	671	252	590	150	77	84	750x320x295
100TBZ5.5	100	283	208	686	252	590	150	77	84	750x320x295
100TBZ7.5	100	330	240	764	314	676	190	106	116	835x365x385
150TBZ7.5	150	330	240	790	314	676	190	108	119	865x365x385
100TBZ11	100	373	255	807	350	695	190	136	148	885x415x435
150TBZ11	150	373	255	807	350	695	190	139	150	885x415x435
100TBZ15	100	373	255	842	350	755	190	144	158	935x415x435
150TBZ15	150	373	255	842	350	755	190	146	160	935x415x435

Material of Construction

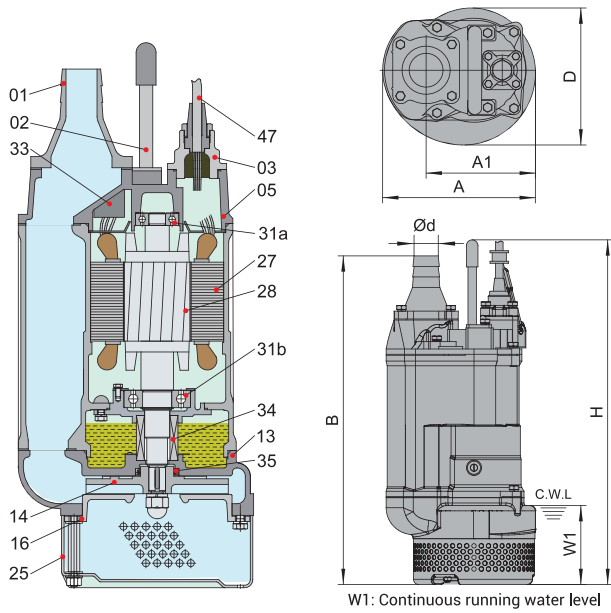

Item No.	Part name	Material
01	Hose coupling	Cast iron
02	Handle	Rubber&steel
05	Upper cover	Cast iron
11	Motor body	Cast iron
13	Pump body	Cast iron
14	Impeller	High chrome alloy
16	Inlet plate	Ductile iron
25	Strainer	Steel
27	Stator	
28	Rotor	Shaft: AISI420SS
31a	Bearing	Ball bearing
31b	Bearing	Ball bearing
33	Motor protector	
34	Mechanical seal	Sic-Sic/Carbon-Sic(2.2 kW); Sic-Sic/Sic-Sic (≥3.7 kW)
35	Oil seal	
47	Cable	

Performance Range

Model (50Hz)	Outlet mm	Motor power		Rated current (400V) A	Rated capacity		Rated head m	Max capacity		Max head m	Impeller passage mm
		kW	HP		m³/h	m³/min		m³/h	m³/min		
50TBZ1.5	50	1.5	2	3.5	15	0.25	15	27	0.45	22	8.5
80TBZ1.5	80	1.5	2	3.5	30	0.50	8	40	0.67	14.5	8.5
50TBZ2.2	50	2.2	3	5.0	18	0.30	20	33	0.55	26	8.5
80TBZ2.2	80	2.2	3	5.0	36	0.60	11	55	0.92	19	8.5
50TBZ3.7	50	3.7	5	7.7	12	0.20	30	33	0.55	34	8.5
80TBZ3.7	80	3.7	5	7.7	30	0.50	20	55	0.92	29	8.5
100TBZ3.7	100	3.7	5	7.7	60	1.0	11.5	90	1.50	18.5	8.5
80TBZ5.5	80	5.5	7.5	11.4	36	0.60	25	75	1.25	34	8.5
100TBZ5.5	100	5.5	7.5	11.4	60	1.0	16	105	1.75	23	8.5
100TBZ7.5	100	7.5	10	15	48	0.80	30	84	1.40	40	11.5
150TBZ7.5	150	7.5	10	15	90	1.60	15	124.8	2.08	31	19.5
100TBZ11	100	11	15	22	60	1.0	35	84	1.40	48.5	11.5
150TBZ11	150	11	15	22	102	1.70	22	147	2.45	32	19.5
100TBZ15	100	15	20	29.5	60	1.0	42	84	1.40	56	11.5
150TBZ15	150	15	20	29.5	102	1.70	30	156	2.60	40	19.5

Performance Curves

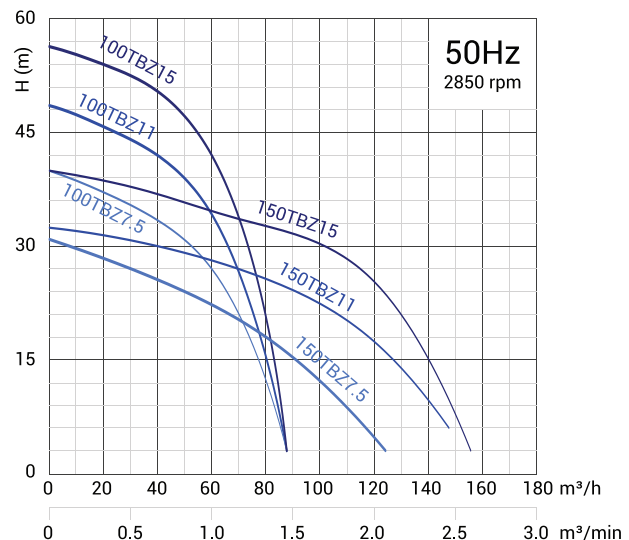
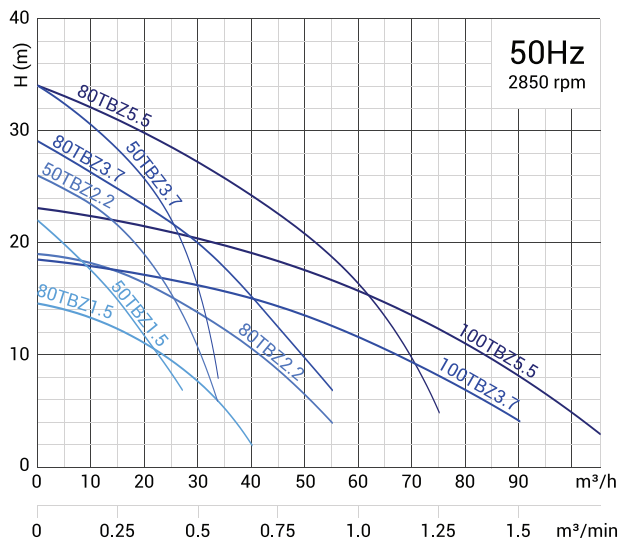

TBZE AUTOMATIC SUBMERSIBLE CONTRACTORS' DEWATERING PUMP



TBZE-series robust pumps are best suited for draining in civil engineering, but can be also used for general pumping purposes.

Motor and pump casing is made of rigid cast iron for long-lasting durability. Maximum submersion depth is greatly increased due to mechanical seal resistant to high pressure. Semi-open impeller made of high chrome alloy in combination with wear plate (ductile iron) achieves superior durability.

Effective motor cooling due to execution of discharge channel integrated into the motor housing. Space saving design due to a top outlet.

Discharge outlet from 50mm to 100mm, Motor from 1,5kW to 5,5kW.

TBZE series pumps operate automatically with the help of built-in intelligent control system. This system helps the end-user to achieve electricity cost reduction at the construction or industrial site.

Technical Specifications

- Capacity: up to 105 m³/h
- Head: up to 38 meters
- Power: 1.5 kW to 5,5 kW
- Power supply: Three phase 400V ± 10%, 50Hz
- Insulation class: F
- Protection class: IP68
- Cable length: 20m
- Water temperature: up to 40° C
- Max. water depth: 25m

Application

- Construction sites
- Mining and industrial sites
- Drainage and contaminated water
- General pumping purposes

Optional Features

- Other voltages
- Other length of cable

Key features of TBZE intelligent control system

- Protects against reverse phase, ensuring correct impeller rotation;
- Protects against open phase or impeller jam, thus prevents accidental damage;
- Automatically stops the pump in case of overload, abnormal voltage with the recovery after 5 minutes;
- The pump stops working at high temperature, and will automatically restart after cooling to the specified temperature;
- The water level sensor's height is adjustable to control pump operation;
- The pump stops working within 60seconds when water level is below the water level probe keeping downtime for 180 seconds, after the 180 seconds, meanwhile the water level is above the water level sensor, the pump works again;
- Rapid assessment of the pump's operation and malfunction history.

Material of Construction

Item No.	Part name	Material
01	Hose coupling	Cast iron
02	Handle	Rubber&steel
05	Upper cover	Cast iron
06	Upper support	Cast iron
11	Motor body	Cast iron
13	Pump body	Cast iron
14	Impeller	High chrome alloy
16	Inlet plate	Ductile iron
25	Strainer	Steel
27	Stator	
28	Rotor	Shaft: AISI420SS
31a	Bearing	Ball bearing
31b	Bearing	Ball bearing
34	Mechanical seal	Sic-Sic/Carbon-Sic(≤2,2 kW); Sic-Sic/Sic-Sic (≥3,7 kW)
35	Oil seal	
47	Cable	
86	AC Contactor	
86a	Water level sensor	
88	Controller block	

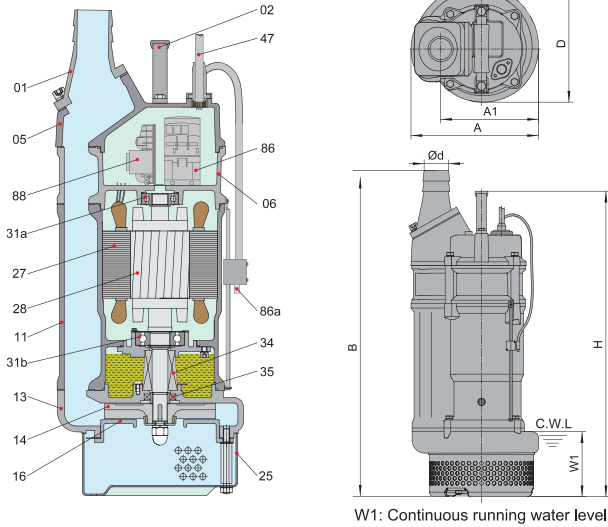

Performance Range

Model (50Hz)	Outlet mm	Motor power		Rated current(400V) A	Rated capacity		Rated head m	Max capacity		Max head m	Impeller passage mm
		kW	HP		m ³ /h	m ³ /min		m ³ /h	m ³ /min		
50TBZE1.5	50	1.5	2	3.5	15	0.25	15	27	0.45	22	8.5
80TBZE1.5	80	1.5	2	3.5	30	0.50	8	40	0.67	14.5	8.5
50TBZE2.2	50	2.2	3	5.0	18	0.30	20	33	0.55	26	8.5
80TBZE2.2	80	2.2	3	5.0	36	0.60	11	55	0.92	19	8.5
50TBZE3.7	50	3.7	5	7.7	12	0.20	30	33	0.55	34	8.5
80TBZE3.7	80	3.7	5	7.7	30	0.50	20	55	0.92	29	8.5
100TBZE3.7	100	3.7	5	7.7	60	1.0	11.5	90	1.50	18.5	8.5
80TBZE5.5	80	5.5	7.5	11.4	36	0.60	25	75	1.25	34	8.5
100TBZE5.5	100	5.5	7.5	11.4	60	1.0	16	105	1.75	23	8.5

Performance Curves

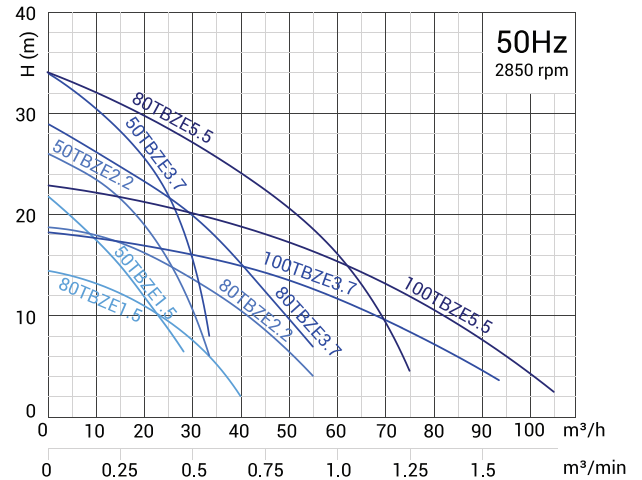

Dimensions and Weight

Model (50Hz)	d	A	A1	B	D	H	W1	N.W.	G.W.	Packing dimension mm
	mm	mm	mm	mm	mm	mm	mm	kg	kg	
50TBZE1.5	50	235	190	613	216	582	120	41	45	680x265x265
80TBZE1.5	80	235	190	620	216	582	120	41	45	680x265x265
50TBZE2.2	50	235	190	613	216	582	120	44	48	680x265x265
80TBZE2.2	80	235	190	620	216	582	120	44	48	680x265x265
50TBZE3.7	50	283	223	703	252	707	150	71	76	770x320x295
80TBZE3.7	80	283	223	703	252	707	150	71	76	770x320x295
100TBZE3.7	100	283	223	728	252	707	150	72	77	770x320x295
80TBZE5.5	80	283	223	755	252	668	150	85.5	92.5	840x350x370
100TBZE5.5	100	283	223	780	252	668	150	86.5	93.5	840x350x370

TBD SUBMERSIBLE AGITATOR PUMP



Solidpump TBD agitator series are cast iron heavy-duty slurry / sand pumps using TBZ pumps as a base.

TBD pumps are equipped with agitators that assist smooth suction of the pumped media.

The side-flow, top-discharge design provide for motor cooling even in case the pump is operated continuously in semisubmerged condition.

TBD pumps are suitable for transferring of water with sand, bentonite slurry and are used for slurry drilling, draining of slurry contaminated water in civil engineering works, cleaning of sand pits, etc.

Technical Specifications

- Capacity: up to 90 m³/h
- Head: up to 30 meters
- Power: 1.5 kW to 3.7 kW
- Power supply: Three phase 400V ± 10%, 50Hz
- Insulation class: F
- Protection class: IP68
- Cable length: 20m
- Water temperature: up to 40° C
- Max. water depth: 25m

Application

- Construction sites
- Mines and quarries
- Sand pits and sedimentation tanks at wastewater treatment plants
- Transfer of bentonite slurry and sandy sludge
- Transfer of water containing mud and sand

Optional Features

- Other voltages
- Other length of cable



Material of Construction

Item No.	Part name	Material
01	Hose coupling	Cast iron
02	Handle	Rubber&steel
05	Upper cover	Cast iron
11	Motor body	Cast iron
13	Pump body	Cast iron
14a	Impeller	High chrome alloy
14b	Agitator	High chrome alloy
16	Inlet plate	Ductile iron
25	Strainer	Steel
27	Stator	
28	Rotor	Shaft: AISI420SS
31a	Bearing	Ball bearing
31b	Bearing	Ball bearing
33	Motor protector	
34	Mechanical seal	Sic-Sic/Carbon-Sic (≤2,2kW); Sic-Sic/Sic-Sic (3.7kW)
35	Oil seal	
47	Cable	

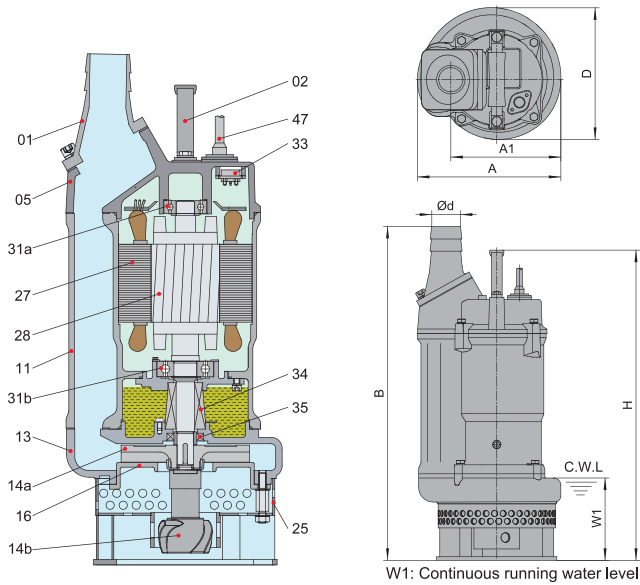

Dimensions and Weight

Model (50Hz)	d	A	A1	B	D	H	W1	N.W.	G.W.	Packing dimension
	mm	mm	mm	mm	mm	mm	mm	kg	kg	mm
50TBD1.5	50	235	173	557	216	522	135	37	41	610x265x265
50TBD2.2	50	235	173	557	216	522	135	40	44	610x265x265
80TBD3.7	80	283	208	636	252	642	165	64	69	710x320x295
100TBD3.7	100	283	208	661	252	642	165	65	70	710x320x295

Performance Range

Model (50Hz)	Outlet	Motor power		Rated current	Rated capacity		Rated head	Max capacity		Max head	Impeller passage
	mm	kW	HP	A	m³/h	m³/min	m	m³/h	m³/min	m	mm
50TBD1.5	50	1.5	2	3.5	15	0.25	15	30	0.50	20	10
50TBD2.2	50	2.2	3	5.0	18	0.3	19	30	0.50	25	10
80TBD3.7	80	3.7	5	7.7	30	0.5	20	60	1.00	30	10
100TBD3.7	100	3.7	5	7.7	60	1.0	11	90	1.50	18	10

Performance Curves

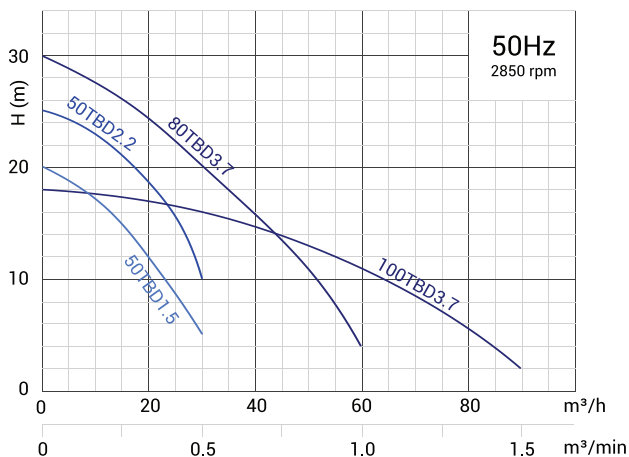

TBDE **AUTOMATIC** **SUBMERSIBLE AGITATOR PUMP**



Solidpump TBD agitator series are cast iron heavy-duty slurry / sand pumps using TBZ pumps as a base. TBDE pumps are equipped with agitators that assist smooth suction of the pumped media.

The side-flow, top-discharge design provide for motor cooling even in case the pump is operated continuously in semisubmerged condition.

TBDE pumps are suitable for transferring of water with sand, bentonite slurry and are used for slurry drilling, draining of slurry-contaminated water in civil engineering works, cleaning of sand pits, etc.

TBDE series pumps operate automatically with the help of built-in intelligent control system. This system helps the end-user to achieve electricity cost reduction at the construction or industrial site.

Technical Specifications

- Capacity: up to 90 m³/h
- Head: up to 30 meters
- Power: 1.5kW to 3.7kW
- Supply voltage: Three phase 400V ± 10%, 50Hz
- Insulation class: F
- Protection class: IP68
- Cable length: 20m
- Water temperature: up to 40° C
- Max. water depth: 25m

Application

- Construction sites
- Mines and quarries
- Sand pits and sedimentation tanks at wastewater treatment plants
- Transfer of bentonite slurry and sandy sludge
- Transfer of water containing mud and sand

Optional Features

- Other voltages
- Other length of cable

Key features of TBDE intelligent control system

- Protects against reverse phase, ensuring correct impeller rotation;
- Protects against open phase or impeller jam, thus prevents accidental damage;
- Automatically stops the pump in case of overload, abnormal voltage with the recovery after 5 minutes;
- The pump stops working at high temperature, and will automatically restart after cooling to the specified temperature;
- The water level sensor's height is adjustable to control pump operation;
- The pump stops working within 60seconds when water level is below the water level probe keeping downtime for 180 seconds, after the 180 seconds, meanwhile the water level is above the water level sensor, the pump works again;
- Rapid assessment of the pump's operation and malfunction history.

Material of Construction

Item No.	Part name	Material
01	Hose coupling	Cast iron
02	Handle	Rubber&steel
05	Upper cover	Cast iron
06	Upper support	Cast iron
11	Motor body	Cast iron
13	Pump body	Cast iron
14a	Impeller	High chrome alloy
14b	Agitator	High chrome alloy
16	Inlet plate	Ductile iron
25	Strainer	Steel
27	Stator	
28	Rotor	Shaft: AISI420SS
31a	Bearing	Ball bearing
31b	Bearing	Ball bearing
34	Mechanical seal	Sic-Sic/Carbon-Sic ($\leq 2,2\text{kW}$); Sic-Sic/Sic-Sic (3.7kW)
35	Oil seal	
47	Cable	
86	AC Contactor	
86a	Water level sensor	
88	Controller block	

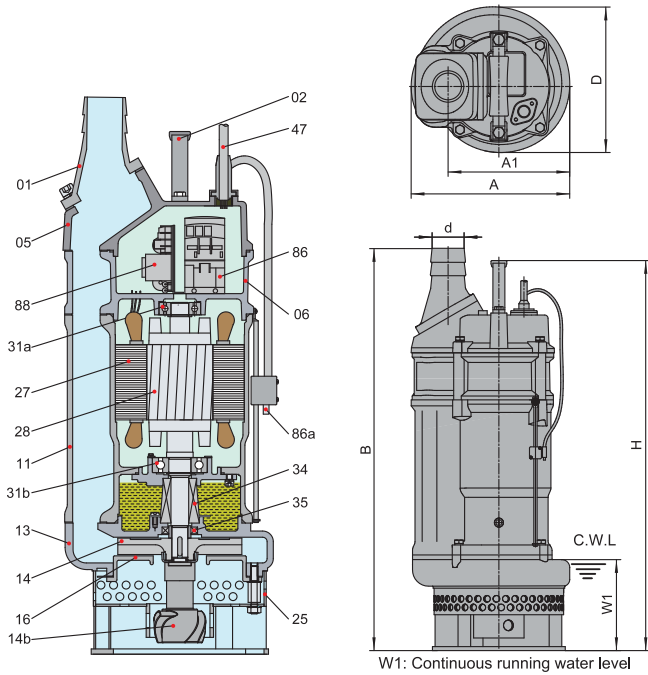

Dimensions and Weight

Model (50Hz)	d	A	A1	B	D	H	W1	N.W.	G.W.	Packing dimension mm
	mm	mm	mm	mm	mm	mm	mm	kg	kg	
50TBDE1.5	50	235	173	629	216	594	135	43	47	680x265x265
50TBDE2.2	50	235	173	629	216	594	135	46	50	680x265x265
80TBDE3.7	80	283	208	714	252	720	165	72	77	770x320x295
100TBDE3.7	100	283	208	739	252	720	165	73	78	770x320x295

Performance Range

Model (50Hz)	Outlet	Motor power		Rated current A	Rated capacity		Rated head m	Max capacity		Max head m	Impeller passage mm
	mm	kW	HP		m ³ /h	m ³ /min		m ³ /h	m ³ /min		
50TBDE1.5	50	1.5	2	3.5	15	0.25	15	30	0.50	20	10
50TBDE2.2	50	2.2	3	5.0	18	0.3	19	30	0.50	25	10
80TBDE3.7	80	3.7	5	7.7	30	0.5	20	60	1.0	30	10
100TBDE3.7	100	3.7	5	7.7	60	1.0	11	90	1.50	18	10

Performance Curves

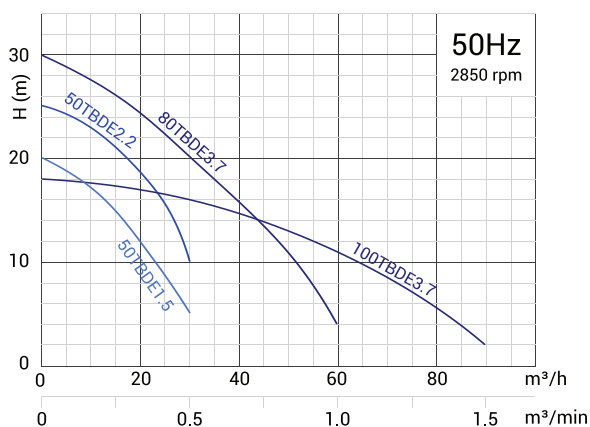

TBS SUBMERSIBLE SAND/SLURRY AGITATOR PUMP



Heavy duty TBS-series sand / slurry pumps with 4-pole motor insure reliable operation and extended working period under rough conditions.

TBS pumps equipped with high-chrome alloy impeller combined with agitator are suitable for transferring of water with sand and slurry and are used in mining, construction and municipal wastewater treatment applications for cleaning of sand pits, bottom deepening, pumping of water containing great amount of slurry, sand and abrasive particles.

Technical Specifications

- Capacity: up to 372 m³/h
- Head: up to 32 meters
- Discharge: 80mm to 200mm
- Power: 4kW to 22kW
- Power supply: Three phase 380V ± 10%, 50Hz
- Insulation class: F
- Protection class: IP68
- Cable length: 20m
- Water temperature: up to 40°C
- Max. water depth: 15m

Application

- Mines and quarries
- Construction sites
- Wastewater treatment plants
- Transfer of water high in slurry, sand and abrasive particles
- Bottom deepening
- Cleaning of sand pits, sludge tanks and tailings' ponds

Optional Features

- Other voltages
- Other length of cable

Dimensions and Weight

Model (50Hz)	d mm	A mm	A1 mm	B mm	B1 mm	D mm	H mm	W1 mm	N.W. kg	G.W. kg	Packing dimension mm
80TBS4	80	350	260	816	678	326	730	250	108,5	119	395x385x885
100TBS6	100	415	305	844	682	373	730	250	141	151	470x410x985
150TBS9	150	434	324	889	727	407	776	250	171	183	470x470x1045
200TBS15	200	484	352	1121	889	457	980	295	260	278	540x500x1220
200TBS22	200	578	442	1245	1015	528	1200	330	408	434	740x570x1460

Material of Construction

Item No.	Part name	Material
01	Hose coupling	Cast iron
02	Handle	Steel
05	Upper cover	Cast iron
07	Bearing house	Cast iron
11	Motor body	Cast iron
13	Pump body	Cast iron
14a	Impeller	High chrome alloy
14b	Agitator	High chrome alloy
16a	Inlet plate	High chrome alloy
16b	Inlet plate	Cast iron
25	Strainer	Steel
27	Stator	
28	Rotor	Shaft: AISI420SS
31a	Bearing	Ball bearing
31b	Bearing	Ball bearing
34	Mechanical seal	Sic-Sic/Sic-Sic; Tc-Sic/Sic-Sic (>15kW)
35	Oil seal	
47	Cable	

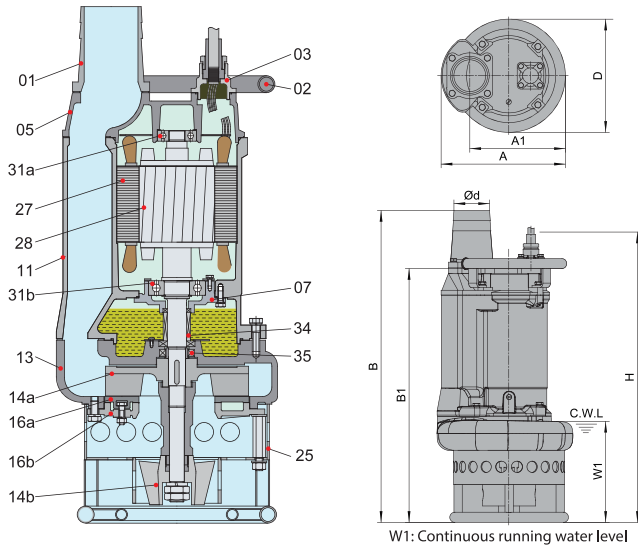

Performance Range

Model (50Hz)	Outlet mm	Motor power		Starting method	Rated current (380V) A	Rated capacity		Rated head m	Max capacity		Max head m	Impeller passage mm
		kW	HP			m ³ /h	m ³ /min		m ³ /h	m ³ /min		
80TBS4	80	4	5.5	D.O.L.	10.2	60	1.0	10	99	1.65	14.8	30
100TBS6	100	6	8	D.O.L.	13.8	90	1.50	10	144	2.40	16.9	30
150TBS9	150	9	12	D.O.L.	19.5	100	1.67	15	192	3.20	21.5	30
200TBS15	200	15	20	D.O.L.	30.1	200	3.33	16	372	6.20	22	30
200TBS22	200	22	30	Star-Delta	42	200	3.33	24	360	6	32	30

Performance Curves

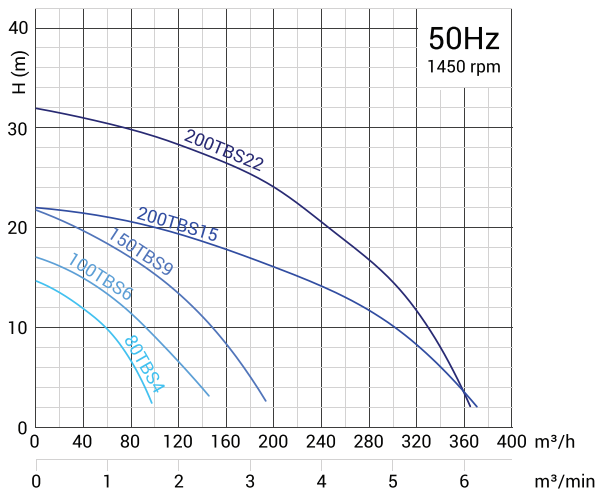

TTZ SUBMERSIBLE AGITATOR PUMP



TTZ-series agitator pumps handle smooth passage of slime and sandy sludge.

TTZ pumps feature 4-pole motor, high-chrome alloy impeller combined with agitator, which ensure reliable operation and extended working period.

Technical Specifications

- Capacity: up to 114 m³/h
- Head: up to 15 meters
- Discharge: from 80mm to 100mm
- Power: 2.2kW to 3.7kW
- Supply supply: Three phase 400V ± 10%, 50Hz
- Insulation class: F
- Protection class: IP68
- Cable length: 20m
- Water temperature: up to 40°C
- Max. water depth: 20m

Application

- Industrial and construction sites
- Mines and quarries
- Wastewater treatment plants
- Transfer of sandy sludge and slime
- Transfer of water containing mud and sand

Optional Features

- Other voltages
- Other length of cable



Material of Construction

Item No.	Part name	Material
01	Hose coupling	Cast iron
02	Handle	Steel
05	Upper cover	Cast iron
06	Up-bearing house	Cast iron
07	Bearing house	Cast iron
10	Seal house	Cast iron
11	Motor body	Cast iron
12	Outer casing	Steel
13	Pump body	Cast iron
14a	Impeller	High chrome alloy
14b	Agitator	High chrome alloy
16	Inlet plate	Ductile iron
19	Check value	NBR
22a	Valve seat	Cast iron
22b	Seat assembly	Cast iron
25	Strainer	Steel
27	Stator	
28	Rotor	Shaft: AISI420SS
31a	Bearing	Ball bearing
31b	Bearing	Ball bearing
33	Motor protector	
34	Mechanical seal	
35	Oil seal	
47	Cable	

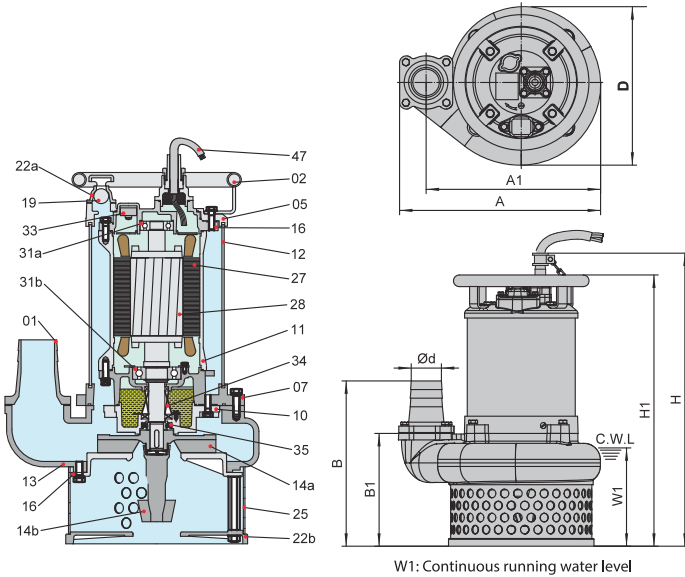

Dimensions and Weight

Model (50Hz)	d mm	A mm	A1 mm	B mm	B1 mm	D mm	H mm	H1 mm	W1 mm	N.W. kg	G.W. kg	Packing dimension mm
80TTZ2.2	80	469	408	378	257	371	685	625	230	92	99	765x405x495
80TTZ3.7	80	469	408	378	257	371	750	690	230	108	116	830x405x495
100TTZ3.7	100	469	408	392	257	371	750	690	230	108	116	830x405x495

Performance Range

Model (50Hz)	Outlet	Motor power		Rated current (400V)	Rated capacity		Rated head	Max capacity		Max head	Impeller passage
	mm	kW	HP	A	m³/h	m³/min	m	m³/h	m³/min	m	mm
80TTZ2.2	80	2.2	3	5.5	36	0.6	10	72	1.2	12	20
80TTZ3.7	80	3.7	5	8.1	36	0.6	13.5	86.4	1.44	15	20
100TTZ3.7	100	3.7	5	8.1	60	1.0	11	114	1.9	15	20

Performance Curves

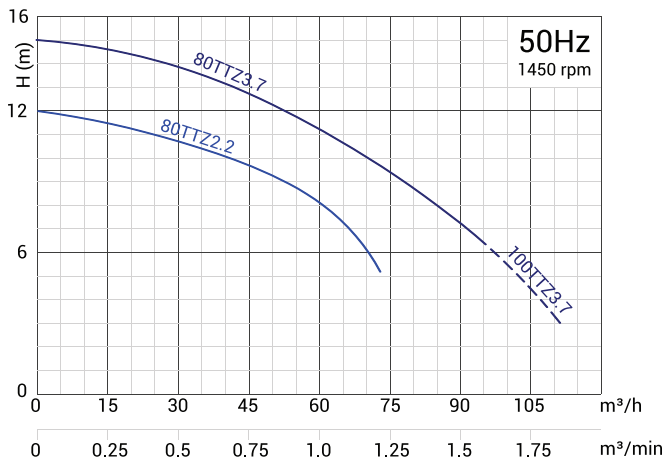

MH 22-45 kW HIGH HEAD DEWATERING PUMP



MH-series submersible pumps with a strong construction are designed to withstand the high pressure during deep well dewatering.

Motor and pump casing is made of rigid cast iron for long-lasting durability.

Maximum submersion depth is greatly increased due to special mechanical seal resistant to high pressure.

Motor is cooled by the pumped water for safe operation even in case the pump is operated continuously in semisubmerged condition.

Space saving design due to a top outlet.

Discharge from 100mm to 200mm, motor 22kW to 45kW. Pumps are equipped with dry type submersible induction motors (2 poles).

Technical Specifications

- Capacity: up to 372 m³/h
- Head: up to 90 meters
- Power: 22kW to 45kW
- Power supply: Three phase 400V ± 10%, 50Hz
- Insulation class: F
- Protection class: IP68
- Cable length: 20 m
- Water temperature: up to 40°C
- Max. water depth: 30 m

Application

- Mining and industrial sites
- Construction sites
- Deep-well and high-head dewatering
- Drainage and contaminated water
- General pumping purposes

Optional Features

- Other voltages
- Other length of cable

Dimensions and Weight

Model (50Hz)	A mm	B mm	C mm	n-Ød mm	D mm	H mm	H1 mm	W1 mm	N.W. kg	G.W. kg	Packing dimension mm
100MH22	100	180	220	8-Ø17.5	420	1374	1072	240	370	410	620x740x1540
100MH30	100	180	220	8-Ø17.5	420	1374	1072	240	375	415	620x740x1540
150MH22	150	240	285	8-Ø22	420	1434	1082	250	385	425	620x740x1600
150MH30	150	240	285	8-Ø22	420	1434	1082	250	390	430	620x740x1600
150MH37	150	240	285	8-Ø22	530	1424	1072	180	570	615	680x740x1650
150MH45	150	240	285	8-Ø22	530	1424	1072	180	575	620	680x740x1650
200MH37	200	295	340	12-Ø22	530	1474	1072	180	575	625	680x740x1700
200MH45	200	295	340	12-Ø22	530	1474	1072	180	580	630	680x740x1700

Material of Construction

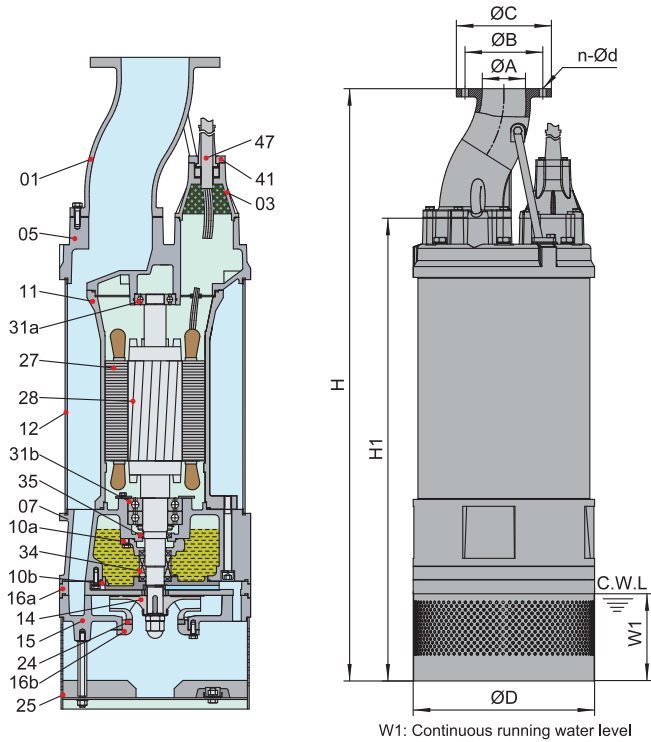

Item No.	Part name	Material
01	Hose coupling	Ductile iron
03	Terminal box	Cast iron
05	Upper cover	Cast iron
07	Bearing house	Cast iron
10a	Seal bracket	Cast iron
10b	Seal bracket	Cast iron
11	Motor body	Cast iron
12	Outer casing	Steel
14	Impeller	High chrome alloy
15	Diffuser	Ductile iron
16a	Inlet plate	Ductile iron
16b	Inlet plate	Ductile iron
24	Neck ring	High chrome alloy
25	Strainer	AISI304SS
27	Stator	
28	Rotor	Shaft: AISI420SS
31a	Bearing	Ball bearing
31b	Bearing	Ball bearing
34	Mechanical seal	Tc-Sic/Sic-Sic
35	Oil seal	
41	Shim	Cast iron
47	Cable	

Performance Range

* Starting method: Star-Delta

Model (50Hz)	Outlet	Motor power		Rated current	Rated capacity		Rated head	Max capacity		Max head	Impeller passage
	mm	kW	HP	A	m ³ /h	m ³ /min	m	m ³ /h	m ³ /min	m	mm
100MH22	100	22	30	41.5	66	1.1	60	130	2.17	68	6
100MH30	100	30	40	54	72	1.2	70	170	2.83	78	6
150MH22	150	22	30	41.5	120	2.0	37	200	3.33	50	15
150MH30	150	30	40	54	140	2.33	45	220	3.37	58	15
150MH37	150	37	50	66	60	1.0	80	220	3.67	83	6
150MH45	150	45	60	80	84	1.4	80	220	3.67	90	6
200MH37	200	37	50	66	216	3.6	35	330	5.5	48	20
200MH45	200	45	60	80	270	4.5	35	372	6.2	53	20

Performance Curves

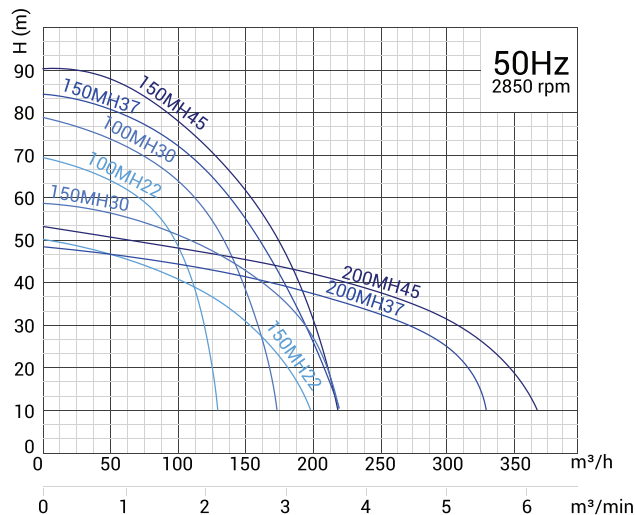

MH 55-110 kW HIGH HEAD DEWATERING PUMP



MH-series submersible pumps with a strong construction are designed to withstand the high pressure during deep well dewatering.

Motor and pump casing is made of rigid cast iron for long-lasting durability.

Maximum submersion depth is greatly increased due to special mechanical seal resistant to high pressure.

Motor is cooled by the pumped water for safe operation even in case the pump is operated continuously in semisubmerged condition.

Space saving design due to a top outlet.

Discharge from 150mm to 200mm, motor 55kW to 110kW. Pump is equipped with dry type submersible induction motor (2 poles).

Technical Specifications

- Capacity: up to 408 m³/h
- Head: up to 184 meters
- Power: 55kW to 110kW
- Supply voltage: Three Phase 400V± 10%,50Hz
- Insulation class: F
- Protection class: IP68
- Cable length: 20 m
- Water temperature: up to 40°C
- Max. water depth: 20 m

Application

- Mining and industrial sites
- Construction sites
- Deep-well and high-head dewatering
- Drainage and contaminated water
- General pumping purposes

Optional Features

- Other voltages
- Other length of cable

Dimensions and weight

Model (50Hz)	A mm	B mm	C mm	n-Ød mm	D mm	H mm	H1 mm	W1 mm	N.W. kg	G.W. kg	Packing dimension mm
150MH55	150	240	285	8-Ø22	550	1630	1280	200	830	880	1760x620x940
150MH75	150	240	285	8-Ø22	550	1630	1280	200	830	880	1760x620x940
150MH90	150	250	300	8-Ø26	592	1687	1282	200	1100	1160	1825x665x965
150MH110	150	250	300	8-Ø26	592	1687	1282	200	1130	1190	1825x665x965
200MH55	200	295	340	12-Ø22	550	1680	1280	200	880	930	1810x620x940
200MH75	200	295	340	12-Ø22	550	1680	1280	200	880	930	1810x620x940
200MH90	200	295	340	12-Ø22	592	1687	1282	200	1120	1160	1825x665x965
200MH110	200	295	340	12-Ø22	592	1687	1282	200	1150	1210	1825x665x965

Material of Construction

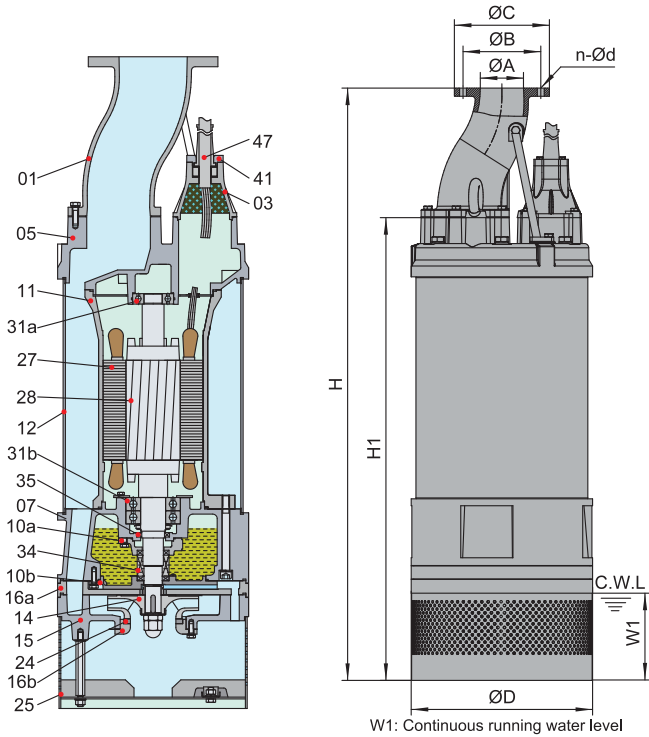

Item No.	Part name	Material
01	Hose coupling	Ductile iron
03	Terminal box	Cast iron
05	Upper cover	Cast iron
07	Bearing house	Cast iron
10a	Seal bracket	Cast iron
10b	Seal bracket	Cast iron
11	Motor body	Cast iron
12	Outer casing	Steel
14	Impeller	High chrome alloy
15	Diffuser	Ductile iron
16a	Inlet plate	Ductile iron
16b	Inlet plate	Ductile iron
24	Neck ring	High chrome alloy
25	Strainer	AISI304SS
27	Stator	
28	Rotor	Shaft: AISI420SS
31a	Bearing	Ball bearing
31b	Bearing	Ball bearing
34	Mechanical seal	Tc-Sic/Sic-Sic
35	Oil seal	
41	Shim	Cast iron
47	Cable	

Performance Range

* Starting method: Star-Delta

Model (50Hz)	Outlet	Motor power		Rated current	Rated capacity		Rated head	Max capacity		Max head	Impeller passage
	mm	kW	HP		A	m ³ /h		m ³ /min	m ³ /h		
150MH55	150	55	75	98	90	1.5	95	192	3.2	105	8
150MH75	150	75	100	132	90	1.5	120	198	3.3	130	8
150MH90	150	90	120	162	120	2.0	120	150	2.5	155	10
150MH110	150	110	150	198	120	2.0	150	180	3.0	177	10
200MH55	200	55	75	98	240	4.0	50	330	5.5	65	20
200MH75	200	75	100	132	270	4.5	60	390	6.5	70	20
200MH90	200	90	120	162	270	4.5	70	360	6.0	90	20
200MH110	200	110	150	198	270	4.5	90	390	6.5	107	20

Performance Curves

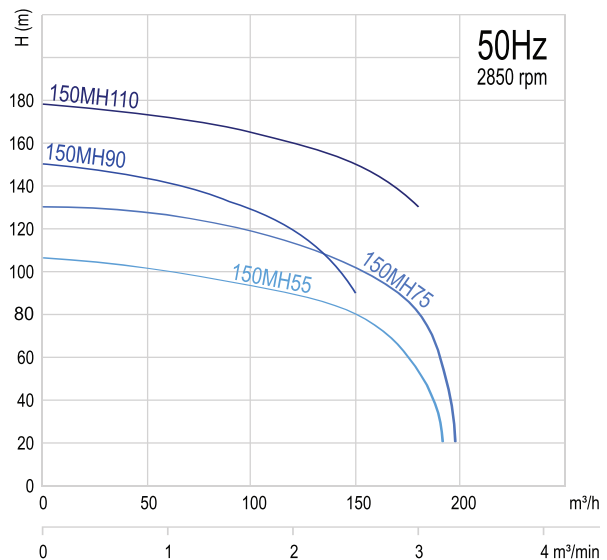
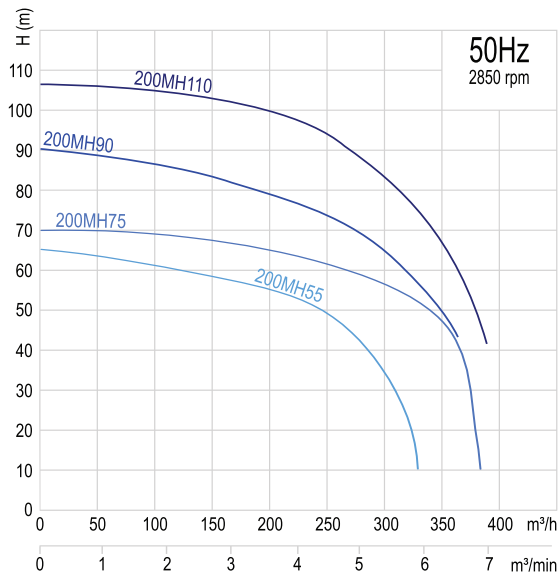

TSM SUBMERSIBLE DRAINAGE PUMP



TSM series Solidpump are compact, high-performance durable 1-phase submersible pumps used for handling abrasive and/or corrosive liquids at the tough job sites, including mines, industries, public utilities and construction sites.

The pump body and parts in contact with water are built of cast iron or stainless steel (at the customer's option). Depending on application, pumps are equipped with semi-open impeller made of high-chrome alloy or stainless steel.

Effective motor cooling due to execution of discharge channel integrated into the motor housing. Discharge outlet from 50mm to 80mm, Motor from 0,25kW to 1,5kW. Hermetically sealed motors are equipped with build-in thermal protection.

Technical Specifications

- Capacity: up to 42 m³/h
- Head: up to 21 m
- Power: 0.25 kW to 1,5kW
- Power supply: single phase 220 V ± 10%, 50 Hz
- Insulation class: F
- Protection class: IP68
- Water temperature: up to 40° C
- Max. water depth:
TSM 0.25 ~ 0.75 kW: 10 m; TSM 1.5 kW: 25 m

Application

- Construction sites
- Mining and industrial sites
- Drainage and contaminated water
- General pumping purposes

Optional Features

- Other voltages
- The length of cable is optional



Material of Construction

Item No.	Part name	Material
01*	Hose coupling	Cast iron
02*	Handle	Rubber&steel
05a*	Upper cover	Cast iron
05b*	Upper cover	Cast iron
06	Up-bearing house	Cast iron
07*	Bearing house	Cast iron
10*	Seal bracket	Cast iron
11	Motor casing	Stainless steel
12	Outer casing	AISI304SS
14*	Impeller	High chrome alloy
15*	Diffuser	Ductile iron
25*	Strainer	Steel
27	Stator	
28	Rotor	Shaft: AISI420SS
31a	Bearing	Ball bearing
31b	Bearing	Ball bearing
32	Capacitor	(Single phase only)
33	Motor protector	
34	Mechanical seal	Sic-Sic/Carbon-Sic ($\leq 2.2\text{kW}$); Sic-Sic/Sic-Sic (3.7-5.5kW)
35	Oil seal	
47	Cable	Length 15 m H07RN-F

* Optional: AISI304SS

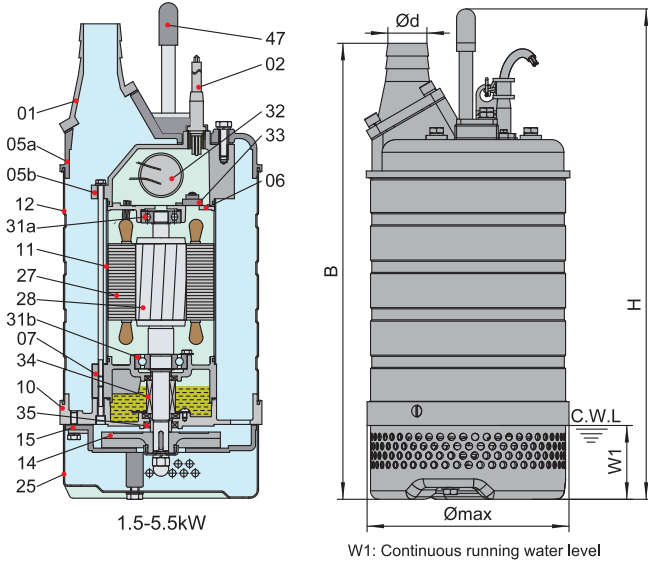

Performance Range

Model (50Hz)	Outlet	Motor power		Voltage	Rated current	Rated capacity		Rated head	Max capacity		Max head	Impeller passage	N.W	G.W	Packing dimension
	mm	kW	HP	V	A	m ³ /h	m ³ /min	m	m ³ /h	m ³ /min	m	mm	kg	kg	mm
50TSM0.25(F)	50	0.25	0.35	220	2.0	6	0.1	7	12	0.2	8	6	14	15	385x225x250
50TSM0.4(F)	50	0.4	0.55	220	3.0	8	0.13	10	14.5	0.24	12	6	15	16	385x225x250
50TSM0.75(F)	50	0.75	1	220	5.0	10	0.17	12	19.5	0.32	15	6	17	18	405x225x250
50TSM1.5(F)	50	1.5	2	220	10	15	0.25	15	30	0.5	21	8.5	37	41	660x270x315
80TSM1.5(F)	80	1.5	2	220	10	27	0.45	9	42	0.7	14	8.5	37	41	660x270x315

F: With float switch

Performance Curves

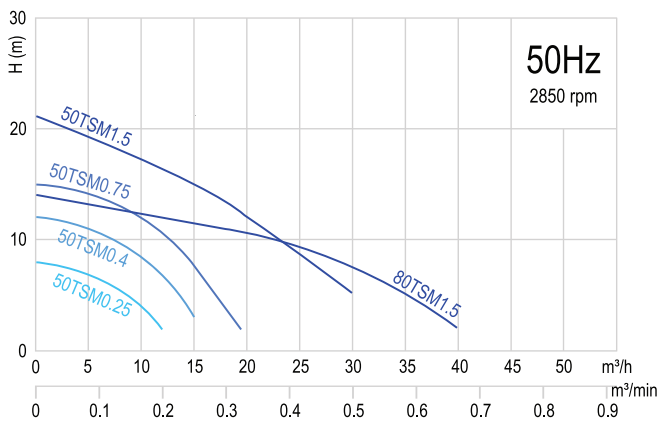

Dimensions

Model	H	B	Ømax	W1
50TSM0.25(F)	345	342	184	50
50TSM0.4(F)	345	342	184	50
50TSM0.75(F)	365	362	184	50
50TSM1.5(F)	582	560	240	87
80TSM1.5(F)	582	567	240	87

B: The height from pump's bottom to outlet
H: The height from pump's bottom to handle's top

TS STAINLESS STEEL DRAINAGE PUMP



Submersible stainless steel TS series pumps are used for transportation of chemically aggressive and abrasive liquids at mining and industrial sites. All parts of pumps in contact with water are made of stainless steel.

Effective motor cooling due to execution of discharge channel integrated into the motor housing.

Discharge outlet from 50mm to 150mm, Motor from 1,5kW to 11kW. Hermetically sealed motors are equipped with build-in thermal protection.

Technical Specifications

- Capacity: up to 150 m³/h
- Head: up to 50 m
- Power: 1.5 kW to 11kW
- Power supply: three phase 400 V ± 10%, 50 Hz
- Insulation class: F
- Protection class: IP68
- Water temperature: up to 40° C
- Max. water depth: 25 m

Application

- Industrial sites
- Mining sites and quarries
- Drainage and contaminated water
- Wastewater treatment plants

Optional Features

- Other voltages
- The length of cable is optional

Dimensions

Model	H	B	Ømax	W1
50TS1.5	563	540	240	87
50TS1.5(F)	563	547	240	87
80TS1.5	563	540	240	87
80TS1.5(F)	563	547	240	87
50TS2.2	613	590	240	87
50TS2.2(F)	613	597	240	87
80TS2.2	613	590	240	87
80TS2.2(F)	613	597	240	87
50TS3.7	515	591	300	76
50TS3.7(F)	515	591	300	76
80TS3.7	515	616	300	76
80TS3.7(F)	555	631	300	76
100TS3.7	555	656	300	76
100TS3.7(F)	565	641	300	76
80TS5.5	565	641	300	76
80TS5.5(F)	565	666	300	76
100TS5.5	605	681	300	76
100TS5.5(F)	605	706	300	76
100TS7.5	700	810	355	142
150TS7.5	700	810	355	142
100TS11	745	855	355	142
150TS11	745	855	355	142

Performance Curves

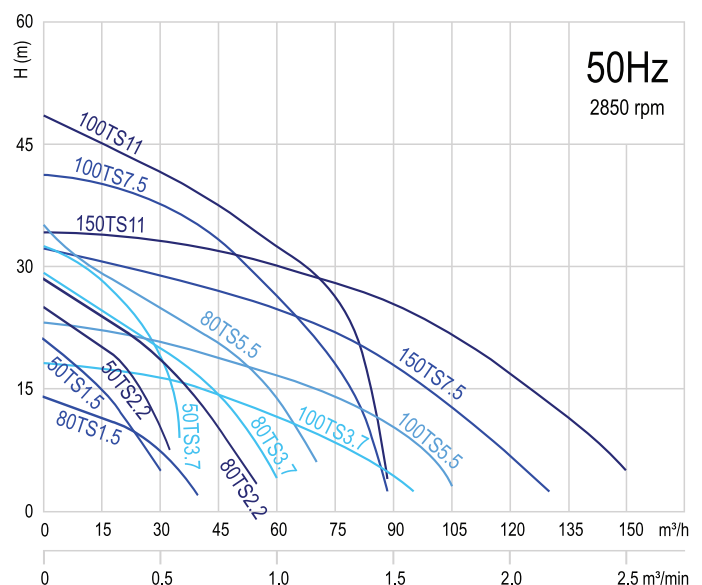

B: The height from pumps bottom to outlet
H: The height from pumps bottom to handles top

Material of Construction

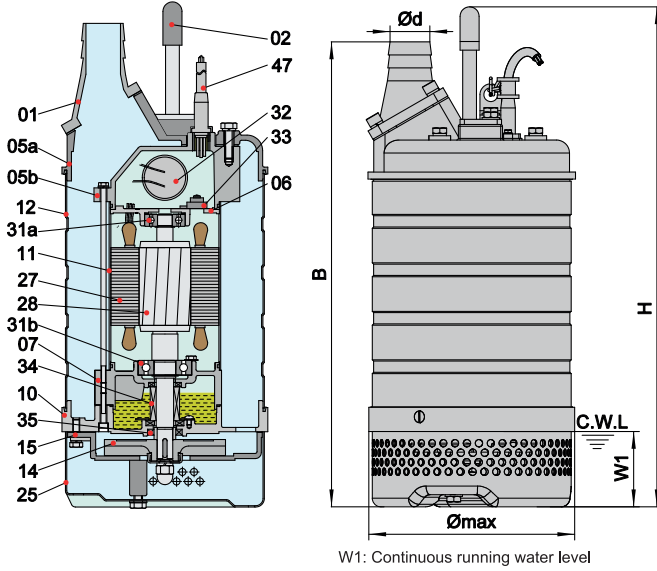

Item No.	Part name	Material
01	Hose coupling	AISI304SS
02	Handle	Rubber&steel
05a	Upper cover	AISI304SS
05b	Upper cover	AISI304SS
06	Up-bearing house	AISI304SS
07	Bearing house	AISI304SS
10	Seal bracket	AISI304SS
11	Motor casing	Stainless steel
12	Outer casing	AISI304SS
14	Impeller	AISI304SS
15	Diffuser	AISI304SS
25	Strainer	AISI304SS
27	Stator	
28	Rotor	Shaft: AISI420SS
31a	Bearing	Ball bearing
31b	Bearing	Ball bearing
32	Capacitor	(Single phase only)*
33	Motor protector	
34	Mechanical seal	Sic-Sic/ Carbon-Sic (≤2.2 kW); Sic-Sic/Sic-Sic (3.7-5.5 kW)
35	Oil seal	
47	Cable	Length 15 m H07RN-F

*- 1,5 kW pumps can be manufactured 220V on request

Performance Range

Model (50Hz)	Outlet	Motor power		Voltage V	Rated current A	Rated capacity		Rated head m	Max capacity		Max head m	Impeller passage mm	N.W kg	G.W kg	Packing dimension mm
	mm	kW	HP			m ³ /h	m ³ /min		m ³ /h	m ³ /min					
50TS1.5	50	1.5	2	400	3.5	15	0.25	15	30	0.5	21	8.5	37	41	620x270x315
50TS1.5(F)	50	1.5	2	400	3.5	15	0.25	15	30	0.5	21	8.5	39	43	690x270x315
80TS1.5	80	1.5	2	400	3.5	27	0.45	9	42	0.7	14	8.5	37	41	620x270x315
80TS1.5(F)	80	1.5	2	400	3.5	27	0.45	9	42	0.7	14	8.5	39	43	690x270x315
50TS2.2	50	2.2	3	400	5.0	20	0.33	18	32	0.53	25	8.5	40	44	620x270x315
50TS2.2(F)	50	2.2	3	400	5.0	20	0.33	18	32	0.53	25	8.5	42	46	690x270x315
80TS2.2	80	2.2	3	400	5.0	36	0.6	11	55	0.92	18.5	8.5	40	44	620x270x315
80TS2.2(F)	80	2.2	3	400	5.0	36	0.6	11	55	0.92	18.5	8.5	42	46	690x270x315
50TS3.7	50	3.7	5	400	7.7	18	0.3	26	36	0.6	32	8.5	58	64	670x320x345
50TS3.7(F)	50	3.7	5	400	7.7	18	0.3	26	36	0.6	32	8.5	60	66	730x320x345
80TS3.7	80	3.7	5	400	7.7	35	0.58	18.5	60	1.0	29	8.5	58	64	670x320x345
80TS3.7(F)	80	3.7	5	400	7.7	35	0.58	18.5	60	1.0	29	8.5	60	66	730x320x345
100TS3.7	100	3.7	5	400	7.7	60	1.0	11.5	95	1.58	18	8.5	59	65	670x320x345
100TS3.7(F)	100	3.7	5	400	7.7	60	1.0	11.5	95	1.58	18	8.5	61	67	730x320x345
80TS5.5	80	5.5	7.5	400	11.4	45	0.75	22	72	1.2	35	8.5	66	72	710x320x345
80TS5.5(F)	80	5.5	7.5	400	11.4	45	0.75	22	72	1.2	35	8.5	68	74	770x320x345
100TS5.5	100	5.5	7.5	400	11.4	60	1.0	16	105	1.75	23	8.5	67	73	710x320x345
100TS5.5(F)	100	5.5	7.5	400	11.4	60	1.0	16	105	1.75	23	8.5	69	75	770x320x345
100TS7.5	100	7.5	10	400	15	60	1.0	26	88	1.47	41	11.5	108	120	894x394x455
150TS7.5	150	7.5	10	400	15	80	1.33	20.5	130	2.17	32	19.5	110	122	894x394x455
100TS11	100	11	15	400	22	60	1.0	32	86.4	1.44	48.5	11.5	123	135	954x394x455
150TS11	150	11	15	400	22	90	1.5	25	150	2.5	34	19.5	125	137	954x394x455

F: With float switch

NOTES



Lined writing area consisting of multiple horizontal blue lines for text entry.

Solidpump. Solid reliability.

For years, for contractors and mechanical engineers, Solidpump brand has been a sign of high reliability and excellent relation of quality and price, when a submersible pump is needed for the most demanding job.

Solidpump products are manufactured with the use of high-tech materials and have the advantage of know-how and the technical competence applied to achieve the lowest LCC (Life Cycle Costs) together with extended operational life and efficiency.

Constant improvement of design and performance capabilities of pumps is carried out owing to continuous feedback received from end-users and distributors. We perform close quality control and provide engineering services for the clients, starting from the consulting during the choice of the best unit, up to the after-sales service support.

Today, key Solidpump products are submersible contractors' dewatering pumps, submersible sand and slurry pumps and portable professional drainage pumps. Solidpump submersible pumps are applicable in general drainage, construction, mining and industrial sites, wastewater treatment, sludge and sand removal, etc.

Solidpump Europe, located in Latvia, conducts European distribution of Solidpump products, providing an extensive stock of pumps and parts along with qualified technical support to our customers.

Solidpump Europe SIA
Uriekstes iela 14a
Riga, LV-1005
LATVIA
Tel.: + 371 66968996
E-mail: info@solidpump.com
www.solidpump.com

